

# AXOR

DE / Gebrauchsanleitung / Montageanleitung	02
FR / Mode d'emploi / Instructions de montage	02
EN / Instructions for use / assembly instructions	03
IT / Istruzioni per l'uso / Istruzioni per l'installazione	03
ES / Modo de empleo / Instrucciones de montaje	04
NL / Gebruiksaanwijzing / Handleiding	04
DK / Brugsanvisning / Monteringsvejledning	05
PT / Instruções para uso / Manual de instalação	05
PL / Instrukcja obsługi / Instrukcja montażu	06
CS / Návod k použití / Montážní návod	06
SK / Návod na použitie / Montážny návod	07
ZH / 用户手册 / 组装说明	07
RU / Руководство пользователя / Инструкция по монтажу	08
HU / Használati útmutató / Szerelési útmutató	08
FI / Käyttöohje / Asennusohje	09
SV / Bruksanvisning / Monteringsanvisning	09
LT / Vartotojo instrukcija / Montavimo instrukcijos	10
HR / Upute za uporabu / Uputstva za instalaciju	10
TR / Kullanım kılavuzu / Montaj kılavuzu	11
RO / Manual de utilizare / Instrucțiuni de montare	11
EL / Οδηγίες χρήσης / Οδηγία συναρμολόγησης	12
SL / Navodilo za uporabo / Navodila za montažo	12
ET / Kasutusjuhend / Paigaldusjuhend	13
LV / Lietošanas pamācība / Montāžas instrukcija	13
SR / Uputstvo za upotrebu / Uputstvo za montažu	14
NO / Bruksanvisning / Montasjeveiledning	14
BG / Инструкция за употреба / Ръководство за монтаж	15
SQ / Udhëzuesi i përdorimit / Udhëzime rreth montimit	15
AR / دليل الاستخدام / تعليمات التجميع	16

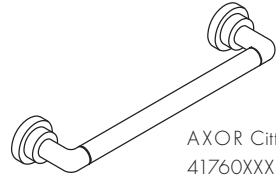

AXOR Citterio  
41760XXX  
41780XXX

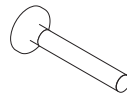

AXOR Citterio  
41528XXX

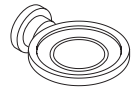

AXOR Citterio  
41733XXX



AXOR Citterio  
41738XXX

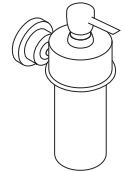

AXOR Citterio  
41719XXX

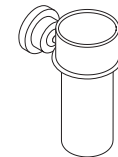

AXOR Citterio  
41734XXX

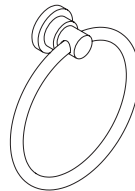

AXOR Citterio  
41721XXX

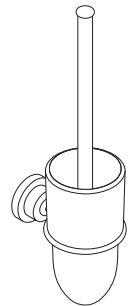

AXOR Citterio  
41735XXX

### ⚠ SICHERHEITSHINWEISE

- ⚠ Bei der Montage müssen zur Vermeidung von Quetsch- und Schnittverletzungen Handschuhe getragen werden.
- ⚠ Es darf ausschließlich nur der Haltegriff 41730XXX zum Festhalten benutzt werden, die übrigen Produkte sind für diesen Einsatzzweck nicht geeignet.
- ⚠ Die ordnungsgemäße Befestigung und der feste Sitz der montierten Produkte ist in periodischen Abständen (jährlich) zu überprüfen.

### MONTAGEHINWEISE

- / Bei der Montage des Produktes durch qualifiziertes Fachpersonal ist darauf zu achten, dass die Befestigungsfläche im gesamten Bereich der Befestigung plan ist (keine vorstehenden Fugen oder Fliesenversatz), der Wandaufbau für eine Montage des Produktes geeignet ist und keine Schwachstellen aufweist.
- / Das Glas enthält Bleioxid.

### SYMBOLERKLÄRUNG



Kein essigsäurehaltiges Silikon verwenden!



MASSE (siehe Seite 17)  
Mundgeblasene Teile - Maßabweichungen berechtigen nicht zu Reklamationen



SERVICETEILE (siehe Seite 23)  
XXX = Farbcodierung  
000 = chrom  
300 = Polished RedGold  
310 = Brushed Red Gold  
330 = Polished Black Chrome  
340 = Brushed Black Chrome  
820 = brushed nickel  
990 = gold-optik



REINIGUNG (siehe Seite 22)  
Zum Füllen und Reinigen Pumpe und Deckel abnehmen.



DEMONTAGE (siehe Seite 21)

MONTAGE (siehe Seite 18) 

### ⚠ CONSIGNES DE SÉCURITÉ

- ⚠ Lors du montage, porter des gants de protection pour éviter toute blessure par écrasement ou coupure.
- ⚠ N'utiliser que la poignée 41730XXX pour se retenir, les autres produits ne convenant pas à cette utilisation.
- ⚠ Vérifier à intervalles réguliers (une fois par an) la fixation correcte et la bonne assise des produits montés

### INSTRUCTIONS POUR LE MONTAGE

- / Lors du montage de ce produit par du personnel qualifié, veiller à ce que la surface de fixation soit bien plane dans toute la zone de fixation (pas de dépassement de joints ou de déport de carreaux), à ce que le mur se prête au montage du produit et ne présente aucun point fragile.
- / Le verre contient de l'oxyde de plomb.

### DESCRIPTION DU SYMBOLE



Ne pas utiliser de silicone contenant de l'acide acétique!



DIMENSIONS (voir pages 17)  
Pièce soufflée artisanalement - Les différences de dimension ne justifient pas une réclamation.



PIÈCES DÉTACHÉES (voir pages 23)  
XXX = Couleurs  
000 = chromé  
300 = Polished RedGold  
310 = Brushed Red Gold  
330 = Polished Black Chrome  
340 = Brushed Black Chrome  
820 = brushed nickel  
990 = or l'optique



NETTOYAGE (voir pages 22)  
Retirer la pompe et le couvercle pour remplir et nettoyer.



DÉMONTAGE (voir pages 21)

MONTAGE (voir pages 18) 

### △ SAFETY NOTES

- △ Gloves should be worn during installation to prevent crushing and cutting injuries.
- △ Use only the handle 41730XXX for support, the remaining products are not intended to be used as supports.
- △ Check the proper attachment and tight seating of the installed products periodically (annually).

### INSTALLATION INSTRUCTIONS

- / During installation of the product by qualified trained personnel, make sure that the entire fastening surface is even and smooth (no protruding seams or tile offset), that the finish of the wall is suitable to apply the product and has no weak points.
- / The glass contains lead oxide.

### SYMBOL DESCRIPTION



Do not use silicone containing acetic acid!



**DIMENSIONS** (see page 17)  
The glass could be of a different size as illustrated due to it being blown by mouth.



**SPARE PARTS** (see page 23)  
XXX = Colors  
000 = chrome plated  
300 = Polished RedGold  
310 = Brushed Red Gold  
330 = Polished Black Chrome  
340 = Brushed Black Chrome  
820 = brushed nickel  
990 = gold plated



**CLEANING** (see page 22)  
Lift off pump and lid for filling and cleaning.



**DISMOUNTING** (see page 21)

**ASSEMBLY** (see page 18) 

### △ INDICAZIONI SULLA SICUREZZA

- △ Durante il montaggio, per evitare ferite da schiacciamento e da taglio bisogna indossare guanti protettivi.
- △ Per tenersi deve essere utilizzato esclusivamente l'impugnatura 41730XXX, gli altri prodotti non sono adatti per questo scopo d'impiego.
- △ Il fissaggio a regola d'arte e la sede fissa dei prodotti montati va controllato a intervallo periodico (annualmente).

### ISTRUZIONI PER IL MONTAGGIO

- / Per il montaggio del prodotto da personale specializzato qualificato bisogna fare attenzione, che la superficie di fissaggio, in tutto il campo di fissaggio, sia piana (nessuna giunzione sporgente o sfalsamento di piastrella), la costruzione della parete sia adatta al montaggio del prodotto e che non presenti alcun punto debole.
- / Il vetro contiene ossido di piombo.

### DESCRIZIONE SIMBOLO



Non utilizzare silicone contenente acido acetico!



**INGOMBRI** (vedi pagg. 17)  
Pezzi soffiati - Non si accettano dei reclami a causa di tolleranze dimensionali



**PARTI DI RICAMBIO**  
(vedi pagg. 23)  
XXX = Trattamento  
000 = cromato  
300 = Polished RedGold  
310 = Brushed Red Gold  
330 = Polished Black Chrome  
340 = Brushed Black Chrome  
820 = brushed nickel  
990 = dorato ottica



**PULITURA** (vedi pagg. 22)  
Per riempire e pulire il contenitore togliere la pompa e il coperchio.



**SMONTAGGIO** (vedi pagg. 21)

**MONTAGGIO** (vedi pagg. 18) 

## △ INDICACIONES DE SEGURIDAD

- △ Durante el montaje deben utilizarse guantes para evitar heridas por aplastamiento o corte.
- △ Solo debe utilizarse exclusivamente la manilla 41730XXX para sujetarse, los demás productos no son adecuados para este uso.
- △ Debe comprobarse en intervalos periódicos (anualmente) que los productos montados estén bien fijados y asentados.

## INDICACIONES PARA EL MONTAJE

- / Durante el montaje del producto, mediante personal especializado, se debe asegurar de que la superficie de sujeción en todo el área de la fijación sea plana (sin fugas o azulejos que sobresalgan), que la estructura del muro sea adecuada para el montaje del producto y que no presente puntos débiles.
- / El vidrio contiene óxido de plomo.

## DESCRIPCIÓN DE SÍMBOLOS



No utilizar silicona que contiene ácido acético!



**DIMENSIONES** (ver página 17)  
Piezas sopladas por la boca - Las diferencias de medida no dan derecho a reclamación



**REPUESTOS** (ver página 23)

XXX = Acabados  
000 = cromado  
300 = Polished RedGold  
310 = Brushed Red Gold  
330 = Polished Black Chrome  
340 = Brushed Black Chrome  
820 = brushed nickel  
990 = oro óptica



**LIMPIAR** (ver página 22)  
Para llenar y limpiar quitar la bomba y la cobertera.



**DESPIECE** (ver página 21)

**MONTAJE** (ver página 18) 

## △ VEILIGHEIDSINSTRUCTIES

- △ Bij de montage moeten ter voorkoming van kniel- en snijwonden handschoenen worden gedragen.
- △ Alleen de handgreep 41730XXX mag gebruikt worden om zich vast te houden, de overige producten zijn voor dat gebruiksdoeleinde niet geschikt.
- △ De reglementaire bevestiging en de vaste zitting van de gemonteerde producten moet regelmatig (jaarlijks) gecontroleerd worden.

## MONTAGE-INSTRUCTIES

- / Bij de montage van het product door gekwalificeerd vakpersoneel moet erop gelet worden dat het montagevlak in het volledige bereik van de bevestiging vlak is (geen uitstekende voegen of verspringende tegels), dat de wand geschikt is voor de montage van het product en geen zwakke plaatsen vertoont.
- / Het glas bevat loodoxyde.

## SYMBOOLBESCHRIJVING



Gebruik geen zuurhoudende silicone!



**MATEN** (zie blz. 17)  
Mondgeblazen materiaal - Maatafwijkingen rechtvaardigen geen reclamaties



**SERVICE ONDERDELEN**  
(zie blz. 23)

XXX = Kleuren  
000 = verchromd  
300 = Polished RedGold  
310 = Brushed Red Gold  
330 = Polished Black Chrome  
340 = Brushed Black Chrome  
820 = brushed nickel  
990 = verguld-look



**REINIGEN** (zie blz. 22)  
Voor het vullen en reinigen pompje en afdekrozet verwijderen.



**DEMONTAGE** (zie blz. 21)

**MONTAGE** (zie blz. 18) 

## △ SIKKERHEDSANVISNINGER

- △ Ved monteringen skal der bruges handsker for at undgå kvæstelser og snitsår.
- △ Man må udelukkende bruge håndtaget 41730XXX til at holde sig fast med. De øvrige produkter er ikke egnet til dette formål.
- △ Den korrekte montering og position af monterede produkter skal kontrolleres i regelmæssige afstande (årligt).

## MONTERINGSANVISNINGER

- / Ved montering af produktet igennem kvalificerede fagfolk skal der holdes øje med, at fastgørelsesoverfladen er plan i alle områder hvor produktet monteres (ingen fremragende fuger eller fliseforskydninger), at væggene er velegnet til monteringen af produktet og ikke har svare områder.
- / Glasset indeholder blyoxid.

## SYMBOLBESKRIVELSE



Der må ikke benyttes eddikesyreholdig silikonel



MÅLENE (se s. 17)

Mundblæste dele - der kan ikke reklameres mod småafvigelser.



RESERVEDELE (se s. 23)

XXX = Overflade

000 = Krom

300 = Polished RedGold

310 = Brushed Red Gold

330 = Polished Black Chrome

340 = Brushed Black Chrome

820 = Brushed nickel

990 = Guld optic



RENGØRING (se s. 22)

Ved påfyldning og rengøring tag da pumpe og låget af.



AFMONTERE (se s. 21)

MONTERING (se s. 18)



## △ AVISOS DE SEGURANÇA

- △ Durante a montagem devem ser utilizadas luvas de protecção, de modo a evitar ferimentos resultantes de entalamentos e de cortes.
- △ Para se segurar ou apoiar só pode 41730XXX utilizar a pega, visto os outros produtos não serem adequados para esse fim.
- △ A fixação e encaixe correctos dos produtos montados devem ser verificados periodicamente (anualmente).

## AVISOS DE MONTAGEM

- / Durante a montagem efectuada por técnicos qualificados deve ter-se em atenção que a superfície de fixação seja plana em toda a sua extensão (sem juntas ou ladrilhos salientes), que a estrutura da parede seja adequada para a montagem do produto e que não apresente pontos fracos.
- / O vidro contém óxido de chumbo.

## DESCRIÇÃO DO SÍMBOLO



Não utilizar silicone que contenha ácido acético!



MEDIDAS (ver página 17)

O vidro poderá apresentar diferenças em relação ao ilustrado devido ao facto de ser feito por sopro.



PEÇAS DE SUBSTITUIÇÃO

(ver página 23)

XXX = Acabamentos

000 = cromado

300 = Polished RedGold

310 = Brushed Red Gold

330 = Polished Black Chrome

340 = Brushed Black Chrome

820 = brushed nickel

990 = ouro ótica



LIMPEZA (ver página 22)

Retirar a bomba e a cobertura para encher e limpar.



DESMONTAR (ver página 21)

MONTAGEM (ver página 18)



## △ WSKAZÓWKI BEZPIECZEŃSTWA

- △ Aby uniknąć zranień na skutek zgniecenia lub przecięcia, podczas montażu należy nosić rękawice ochronne.
- △ Do trzymania się może być używany jedynie uchwyt 41730XXX; pozostałe produkty nie nadają się do tego celu.
- △ W określonym czasie (co roku) należy sprawdzać właściwe zamocowanie i odpowiednie osadzenie zamontowanych produktów.

## WSKAZÓWKI MONTAŻOWE

- / Montaż produktu musi być wykonany przez wykwalifikowanego fachowca. Powierzchnia w miejscu montażu musi być równa (bez uskoków wzgl. wzajemnie przesuniętych płytek). Ściana w miejscu montażu musi być stabilna. Dołożone w komplecie śruby i kołki rozporowe są przeznaczone do betonu.
- / Szkło zawiera tlenek ołowiu.

## OPIS SYMBOLU



Nie stosować silikonów zawierających kwas octowy!



WYMIARY (patrz strona 17)

Ustnie dmuchane elementy - różnice w wymiarach nie podlegają reklamacji



CZĘŚCI SERWISOWE

(patrz strona 23)

XXX = Kody kolorów

000 = chrom

300 = Polished RedGold

310 = Brushed Red Gold

330 = Polished Black Chrome

340 = Brushed Black Chrome

820 = nikiel szorowany

990 = złoty szlachetna



CZYSZCZENIE (patrz strona 22)

Do napętniania i czyszczenia pompy zdjąć klapkę.



DEMONTAŻ (patrz strona 21)

MONTAŻ (patrz strona 18)



## △ BEZPEČNOSTNÍ POKYNY

- △ Pro zabránění řezným zraněním a pohmožděním je nutné při montáži nosit rukavice.
- △ K držení se smí používat výlučně držák 41730XXX, ostatní produkty nejsou vhodné pro tento účel použití.
- △ Upevnění podle předpisů a pevné usazení montovaných produktů je třeba kontrolovat v periodických časových intervalech (ročně).

## POKYNY K MONTÁŽI

- / Při montáži produktu kvalifikovanou osobou je třeba dbát na to, aby byla upevňovací plocha v celé oblasti upevnění rovná (žádné vyčnívající spáry nebo zapuštění obkladů), aby struktura stěny byla vhodná pro montáž produktu a neměla žádná slabá místa.
- / Sklo obsahuje oxid olovnatý.

## POPIS SYMBOLŮ



Nepoužívat silikon s obsahem kyseliny octové!



ROZMĚRY (viz strona 17)

Ručně foukané sklo - rozdíly v rozměrech neopravňují k reklamacji



SERVISNÍ DÍLY (viz strona 23)

XXX = Kód povrchové úpravy

000 = chrom

300 = Polished RedGold

310 = Brushed Red Gold

330 = Polished Black Chrome

340 = Brushed Black Chrome

820 = brushed nickel

990 = zlato ocel



ČIŠTĚNÍ (viz strona 22)

K naplnění a čištění čerpadla sejmout víko.



DEMONTÁŽ (viz strona 21)

MONTÁŽ (viz strona 18)



## △ BEZPEČNOSTNÉ POKYNY

- △ Pri montáži musíte nosiť rukavice, aby ste predišli pomliaždeninám a rezným poraneniam.
- △ Na držanie sa smie používať výlučne držiak 41730XXX, ostatné produkty nie sú vhodné na tento účel použitia.
- △ Upevnenie podľa predpisov a pevné osadenie montovaných produktov treba kontrolovať v periodických časových intervaloch (ročne).

## POKYNY PRE MONTÁŽ

- / Pri montáži produktu kvalifikovanou osobou treba dávať pozor na to, aby bola upevňovacia plocha v celej oblasti upevnenia rovná (žiadne vyčnievajúce medzery alebo zapustenia obkladov), aby štruktúra steny bola vhodná pre montáž produktu a nemá žiadne slabé miesta.
- / Sklo obsahuje oxid olovnatý.

## POPIS SYMBOLOV



Nepoužívať silikón s obsahom kyseliny octovej!



ROZMERY (viď strana 17)

Sklo má byť inej veľkosti než je zobrazené, lebo sa vyfukuje ústami. Nie je nárok na reklamáciu.



SERVISNÉ DIELY (viď strana 23)

XXX = Farebné označenie

000 = chróm

300 = Polished RedGold

310 = Brushed Red Gold

330 = Polished Black Chrome

340 = Brushed Black Chrome

820 = brushed nickel

990 = zlato ocel



ČISTENIE (viď strana 22)

Pri plnení a čistení čerpadla odoberte veko.



DEMONTÁŽ (viď strana 21)

MONTÁŽ (viď strana 18)



## △ 安全技巧

- △ 装配时为避免挤压和切割受伤，必须戴上手套。
- △ 握柄只用于握持41730XXX，其它产品不适用于此项使用用途。
- △ 应定期（每年）检查已装配好的产品是否正常固定和固定定位。

## 安装提示

- / 由有资格的专业人员进行产品安装时请注意：在所有加固区域中，加固表面是否平整（无突出的接缝或瓷砖），墙体结构是否适合产品安装且未显露出任何缺点。
- / 该玻璃含氧化铅。

## 符号说明



请勿使用含有乙酸的硅胶！



大小 (参见第页 17)

玻璃由于使用嘴吹开的，所以尺寸可能与图示不同。



备用零件 (参见第页 23)

XXX = 颜色代码

000 = 镀铬

300 = Polished RedGold

310 = Brushed Red Gold

330 = Polished Black Chrome

340 = Brushed Black Chrome

820 = 镍拉丝

990 = 金色



清洗 (参见第页 22)

升高泵和盖子，用于加注和排放。



拆卸 (参见第页 21)

安装 (参见第页 18)



### ▲ УКАЗАНИЯ ПО ТЕХНИКЕ БЕЗОПАСНОСТИ

- ▲ Во время монтажа следует надеть перчатки во избежание прищемления и порезов.
- ▲ Для фиксации разрешается использовать исключительно рукоятку 41730XXX, остальные изделия непригодны для этой цели.
- ▲ Надлежащее крепление и плотность посадки установленных изделий следует проверять регулярно (ежегодно).

### УКАЗАНИЯ ПО МОНТАЖУ

- / Во время монтажа изделия квалифицированным персоналом поверхность крепления должна быть ровной по всей области крепления (не допускайте выступающих стыков или перекоса облицовочной плитки); для монтажа изделия следует использовать подходящую стену достаточной прочности.
- / Стекло содержит оксид свинца.

### ОПИСАНИЕ СИМВОЛОВ



Не применяйте силикон, содержащий уксусную кислоту.



РАЗМЕРЫ (см. стр. 17)

Делали выполненные способом ручного дутья - отклонения размеров не являются основанием для рекламаций



КОМПЛЕКТ (см. стр. 23)

XXX = Цветная кодировка

000 = хром

300 = Polished RedGold

310 = Brushed Red Gold

330 = Polished Black Chrome

340 = Brushed Black Chrome

820 = brushed nickel

990 = глянцевое золото



ОЧИСТКА (см. стр. 22)

Для наполнения и очистки снимите насос и крышку.



ДЕМОНТАЖ (см. стр. 21)

МОНТАЖ (см. стр. 18) 

### ▲ BIZTONSÁGI UTASÍTÁSOK

- ▲ A szerelésnél a zúzódások és vágási sérülések elkerülése érdekében kesztyűt kell viselni.
- ▲ Kapaszkodáshoz kizárólag csak a kapaszkodót 41730XXX szabad használni, a további termékek nem alkalmasak ilyen jellegű használatra.
- ▲ A felszerelt termékek szabályszerű rögzítését és szilárd elhelyezkedését rendszeres időközönként (évente) ellenőrizni kell.

### SZERELÉSI UTASÍTÁSOK

- / A termék képzett szakember általi felszerelése esetén ügyelni kell arra, hogy a rögzítési felület teljesen sima legyen (ne legyen kiálló fuga vagy csempé), a fal szerkezete a termék felszerelésére alkalmas legyen, és ne legyen gyenge pontja.
- / Az üveg ólom-oxidot tartalmaz.

### SZIMBÓLUMOK LEÍRÁSA



Ne használjon ecetsavtartalmú szilikon!



MÉRETET (lásd a oldalon 17)

Fűvott alkatrészek - a méretbeli eltérések nem jogsítanak fel reklamációra.



TARTOZÉKOK (lásd a oldalon 23)

XXX = Színkódolás

000 = króm

300 = Polished RedGold

310 = Brushed Red Gold

330 = Polished Black Chrome

340 = Brushed Black Chrome

820 = brushed nickel

990 = arany-hatású



TISZTÍTÁS (lásd a oldalon 22)

A röltéshez és tisztításhoz vegye le a szivattyút és a fedelet.



LESZERELÉS (lásd a oldalon 21)

SZERELÉS (lásd a oldalon 18) 



## △ TURVALLISUUSOHJEET

- △ Asennuksessa on käytettävä käsiineitä puristumien ja viiltojen aiheuttamien tapaturmien estämiseksi.
- △ Vain kahvaa saa käyttää kiinnittämiseen 41730XXX, muut tuotteet eivät sovi käytettäväksi siihen tarkoitukseen.
- △ Asennettujen tuotteiden asianmukainen kiinnitys ja tiukkuus on tarkastettava säännöllisin väliajoin (vuosittain).

## ASENNUSOHJEET

- / Pätevän ammattihenkilöstön asentaessa tuotetta on otettava huomioon, että kiinnityspinnan on oltava koko kiinnitysalueelta tasainen (ei korkeita saumoja tai laattojen yhtymäkohtia), seinän rakenne soveltuu tuotteen asennukseen eikä siinä ole heikkoja kohtia.
- / Lasi sisältää lyijyoksidia.

## MERKIN KUVAUS



Älä käytä etikkahappopitoista silikoniala!



MITAT (katso sivu 17)

Käsinpuhalletut osat - mittapoikkeamat eivät ole peruste reklamaation tekemiselle.



VARAOSAT (katso sivu 23)

XXX = Värikoodaus

000 = kromi

300 = Polished RedGold

310 = Brushed Red Gold

330 = Polished Black Chrome

340 = Brushed Black Chrome

820 = harjattu nikkeli

990 = kultaoptiikka



PUHDISTUS (katso sivu 22)

Poista pumppu ja kansi täyttää ja puhdistusta varten.



IRROTUS (katso sivu 21)

## △ SÄKERHETSANVISNINGAR

- △ Handskar ska bäras under monteringsarbetet så att man kan undvika kläm- och skärskadorgen werden.
- △ Det är bara handtaget 41730XXX som får användas till att hålla fast sig i. Övriga produkter är inte lämpliga till detta.
- △ Alla monterade produkter ska kontrolleras regelbundet (varje år) så att de sitter fast ordentligt.

## MONTERINGSANVISNINGAR

- / När kvalificerad fackpersonal monterar produkten är det viktigt att fästyten är plan över hela fästsättningsområdet (inga fogar som sticker ut eller kakelförskjutning) och att väggstrukturen är lämplig för en montering av produkten och inte har några svaga punkter.
- / Glaset innehåller blyoxid.

## SYMBOLFÖRKLARING



Använd inte silikon som innehåller ättiksyra!



MÄTTEN (se sidan 17)

Handtillverkade delar - mätavikelser berättigar inte till reklamationer



RESERVDELAR (se sidan 23)

XXX = Färgkodning

000 = krom

300 = Polished RedGold

310 = Brushed Red Gold

330 = Polished Black Chrome

340 = Brushed Black Chrome

820 = borstad nickel

990 = guld-optik



RENGÖRING (se sidan 22)

Tag bort pump och lock för att fylla och rengöra.



DEMONTERING (se sidan 21)

ASENNUS (katso sivu 18)



MONTERING (se sidan 18)



## SAUGUMO TECHNIKOS NURODYMAI

- △ Apsaugai nuo užspaudimo ir įsijovimo montavimo metu mūvėkite pirštines.
- △ Fiksuoti reikia tik su rankena 41730XXX, kiti gaminiai šiam tikslui nepritaikyti.
- △ Gaminį pritvirtinimo teisingumą ir patikimumą būtina periodiškai (kasmet) tikrinti.

## MONTAVIMO INSTRUKCIJA

- / Atlikdami montavimo darbus, kvalifikuoti darbuotojai turi atkreipti dėmesį, kad pritvirtinimo plokštuma būtų lygi (be išsikišusių siūlių ar perkreiptų plytelių), sienų konstrukcija tiktų gaminiui montuoti ir neturėtų jokių trūkumų.
- / Stiklo Sudėtyje yra švino oksidas.

## SIMBOLIO APRAŠYMAS



Nenaudokite silikono, kurio sudėtyje yra acto rūgšties!



IŠMATAVIMAI (žr. psl. 17)  
Stiklinė gali būti įvairių dydžių



ATSARGINĖS DALYS (žr. psl. 23)

XXX = Spalvos  
000 = chrom  
300 = Polished RedGold  
310 = Brushed Red Gold  
330 = Polished Black Chrome  
340 = Brushed Black Chrome  
820 = brushed nickel  
990 = aukso optika



VALYMAS (žr. psl. 22)  
Valymui nuimkite siurbį ir dangtį.



IŠMONTAVIMAS (žr. psl. 21)

MONTAVIMAS (žr. psl. 18) 

## SIGURNOSNE UPUTE

- △ Prilikom montaže se radi sprječavanja prignječenja i posjekotina moraju nositi rukavice.
- △ Za držanje se smije koristiti isključivo držak 41730XXX, svi ostali proizvodi su za tu svrhu neprikladni.
- △ U redovitim vremenskim razmacima (jednom godišnje) valja provjeravati propisnu pričvršćenost i stabilnost postavljenih proizvoda.

## UPUTE ZA MONTAŽU

- / Kada proizvod montira kvalificirano stručno osoblje treba paziti da čitava površina na koju se učvršćuje bude ravna (bez istaknutih fuga ili krivljenja pločica), da je zidna konstrukcija primjerena montaži proizvoda te da nema slabih mjesta.
- / Staklo ima olovni oksid.

## OPIS SIMBOLA



Nemojte koristiti silikon koji sadrži octenu kiselinu!



MJERE (pogledaj stranicu 17)  
Stakleni dijelovi - različitosti dimenzija ne predstavljaju razlog za reklamaciju proizvoda.



REZERVNI DJELOVI

(pogledaj stranicu 23)  
XXX = Boje  
000 = krom  
300 = Polished RedGold  
310 = Brushed Red Gold  
330 = Polished Black Chrome  
340 = Brushed Black Chrome  
820 = brushed nickel  
990 = optika zlato



ČIŠĆENJE (pogledaj stranicu 22)  
Kod punjenja i čišćenja crpke skinite poklopac



RASTAVLJANJE (pogledaj stranicu 21)

SASTAVLJANJE (pogledaj stranicu 18) 

### ⚠ GÜVENLİK UYARILARI

- ⚠ Montaj esnasında ezilme ve kesilme gibi yaralanmaları önlemek için eldiven kullanılmalıdır.
- ⚠ Tutunmak 41730XXX için sadece tutamak kullanılabilir, diğer ürünler bu kullanıma uygun değildir.
- ⚠ Monte edilmiş ürünlerin talimatlara uygun sabitliği ve sıkı duruşu düzenli aralıklarla (yıllık) kontrol edilmelidir.

### MONTAJ AÇIKLAMALARI

- / Ürünün yetkili uzman personel tarafından montajı yapılırken, sabitleme yüzeyinin sabitleme planının tüm alanında bulunduğu (derz veya fayans kayması olmamalıdır), duvar yapısının ürünün montajı için uygun olduğuna ve zayıf noktaları bulunmadığına dikkat edilmelidir.
- / Cam kurşun oksit içerir.

### SİMGE AÇIKLAMASI



Asetik asit içeren silikon kullanmayın!



ÖLÇÜLERİ (bakınız sayfa 17)  
Ağza üfleme yapan parçalar -ölçü sapmaları- şikayet nedeni değildir



YEDEK PARÇALAR (bakınız sayfa 23)  
XXX = Renkler  
000 = krom  
300 = Polished RedGold  
310 = Brushed Red Gold  
330 = Polished Black Chrome  
340 = Brushed Black Chrome  
820 = brushed nickel  
990 = altın-optik



TEMİZLEME (bakınız sayfa 22)  
Doldurmak ve temizlemek için pompayı ve kapağı çıkartın.



SÖKME (bakınız sayfa 21)

MONTAJI (bakınız sayfa 18)



### ⚠ INSTRUCȚIUNI DE SIGURANȚĂ

- ⚠ La montare utilizați mănuși pentru evitarea contuziunilor și tăierii mâinilor.
- ⚠ Utilizați exclusiv mânăne de sprijin 41730XXX pentru a vă sprijini, celelalte produse nu sunt potrivite pentru a fi utilizate cu acest scop.
- ⚠ Fixarea corespunzătoare și poziția fixă a produselor montate trebuie verificate la intervale regulate (anual).

### INSTRUCȚIUNI DE MONTARE

- / La montarea produsului de către un personal calificat se va avea grijă ca suprafața de fixare să fie plană pe toată aria de fixare (fără proeminențe ale rosturilor sau îmbinări între plăcile de faianță) și ca structura peretelui să fie corespunzătoare pentru fixarea produsului, să nu prezinte locuri cu rezistență redusă.
- / Sticlă conține oxid de plumb.

### DESCRIEREA SIMBOLURILOR



Nu utilizați silicon cu conținut de acid acetic!



DIMENSIUNI (vezi pag. 17)  
Piese fabricate manual - diferențele de dimensiuni nu pot considera motivul unei reclamații.



PIESE DE SCHIMB (vezi pag. 23)  
XXX = Coduri de culori  
000 = crom  
300 = Polished RedGold  
310 = Brushed Red Gold  
330 = Polished Black Chrome  
340 = Brushed Black Chrome  
820 = nichel mat  
990 = auriu optic



CURĂȚARE (vezi pag. 22)  
Pentru umplere și curățare scoateți pompa și capacul.



DEMONTARE (vezi pag. 21)

MONTARE (vezi pag. 18)



### ⚠ ΥΠΟΔΕΙΞΕΙΣ ΑΣΦΑΛΕΙΑΣ

- ⚠ Για να αποφύγετε τραυματισμούς κατά τη συναρμολόγηση πρέπει να φοράτε γάντια.
- ⚠ Μπορεί να χρησιμοποιηθεί αποκλειστικά για κράτημα μόνο η λαβή 41730XXX. Τα υπόλοιπα προϊόντα είναι ακατάλληλα για τη χρήση αυτή.
- ⚠ Θα πρέπει να ελέγχετε ανά διαστήματα (ετησίως) αν η στερέωση εξακολουθεί να είναι επαρκής και αν τα τοποθετημένα προϊόντα στηρίζονται καλά.

### ΟΔΗΓΙΕΣ ΣΥΝΑΡΜΟΛΟΓΗΣΗΣ

- / Κατά τη συναρμολόγηση του προϊόντος από ειδικό προσωπικό θα πρέπει να ελέγχεται με ιδιαίτερη προσοχή η επιφάνεια στερέωσης, αν είναι επίπεδη σε όλη της την επιφάνεια (δεν πρέπει να εξέχουν αρμοί ή πλακάκια), αν η υποδομή του τοίχου είναι κατάλληλη για τη στερέωση του προϊόντος και αν παρουσιάζει ασθενή σημεία.
- / Το γυαλί που περιέχει οξείδιο του μολύβδου.

### ΠΕΡΙΓΡΑΦΗ ΣΥΜΒΟΛΩΝ



Μην χρησιμοποιείτε σιλικόνη που περιέχει οξικό οξύ!



ΔΙΑΣΤΑΣΕΙΣ (βλ. Σελίδα 17)

Τα τμήματα ελεύθερης σηματοδότησης και οι αποκλίσεις από τις διαστάσεις δεν δικαιολογούν τα όποια παράπονα.



ΑΝΤΑΛΛΑΚΤΙΚΑ (βλ. Σελίδα 23)

XXX = Χρώματα  
000 = Επιχρωμιωμένο  
300 = Polished RedGold  
310 = Brushed Red Gold  
330 = Polished Black Chrome  
340 = Brushed Black Chrome  
820 = νίκελ ματ  
990 = οπτική χρυσαύ



ΚΑΘΑΡΙΣΜΟΣ (βλ. Σελίδα 22)

Για την πλήρωση και τον καθαρισμό της αντλίας, να αφαιρείτε το κάλυμμα.



ΑΠΟΣΥΝΑΡΜΟΛΟΓΗΣΗ

(βλ. Σελίδα 21)

ΣΥΝΑΡΜΟΛΟΓΗΣΗ (βλ. Σελίδα 18)



### ⚠ VARNOSTNA OPOZORILA

- ⚠ Pri montaži je treba nositi rokavice, da se preprečijo poškodbe zaradi zmečkanja ali urezov.
- ⚠ Za držanje se sme uporabljati izključno držalni ročaj 41730XXX, preostali proizvodi niso primerni za tovrstno uporabo.
- ⚠ V periodičnih presledkih (letno) je treba preverjati pravilno pritrditvev in trdnost naseda montiranih proizvodov.

### NAVODILA ZA MONTAŽO

- / Pri montaži tega proizvoda s strani kvalificiranega strokovnega osebja je treba paziti na to, da je pritrdilna ploskev na celotni površini za pritrditvev gladka (brez izstopajočih fug ali zasekov ploščic), da je struktura stene primerna za montažo proizvoda in ne kaže šibkih mest.
- / Steklo vsebuje svinčeni oksid.

### OPIS SIMBOLA



Ne smete uporabiti silikona, ki vsebuje očetno kislino!



MERE (glejte stran 17)

Ustno pihani deli - odstopanja v velikosti niso razlog za reklamacijo.



REZERVNI DELI (glejte stran 23)

XXX = Barve  
000 = krom  
300 = Polished RedGold  
310 = Brushed Red Gold  
330 = Polished Black Chrome  
340 = Brushed Black Chrome  
820 = brushed nickel  
990 = pozlačena



ČIŠČENJE (glejte stran 22)

Pri polnjenju in čiščenju snemite črpalko in pokrov.



DEMONTAŽA (glejte stran 21)

MONTAŽA (glejte stran 18)



## △ OHUTUSJUHISED

- △ Kandke paigaldamisel muljumis- ja löikevigastuste vältimiseks kindaid.
- △ Käepidet 41730XXX võib kasutada ainult kinnihoidmiseks, ülejäänud tooted ei sobi selleks kasutusotstarbeks.
- △ Monteeritud toote nõuetekohast paigaldust ja kinnitust tuleb korrapäraselt (kord aastas) kontrollida.

## PAIGALDAMISJUHISED

- / Toote paigaldamisel kvalifitseeritud spetsialistide poolt tuleb jälgida, et kinnituspind oleks kogu ulatuses ühtlaselt tasane (mitte ühtki üleseisvat vuuki või kaldus kahhelkivi), seina ülesehitus toote paigaldamiseks sobiv ja ilma nõrkade kohtadeta.
- / Klaasi sisaldab pliioksiidi.

## △ DROŠĪBAS NORĀDES

- △ Montāžas laikā, lai izvairītos no saspiedumiem un iegriezumiem, nepieciešams nēsāt cimdus.
- △ Turēšanai drīkst izmantot vienīgi rokturi 41730XXX, pārējie produkti nav piemēroti šim nolūkam.
- △ Nepieciešams periodiski (reizi gadā) pārbaudīt, vai uzmontētie produkti ir pareizi piestiprināti un labi turas.

## NORĀDĪJUMI MONTĀŽAI

- / Kvalificētiem speciālistiem, montējot produktu, jāpiegriež vērība tam, lai piestiprināšanas virsma visā piestiprināšanas zonā ir gluda (nav fūgu vai flīžu iecirtumu), sienas uzbūve ir piemērota produkta montāžai un tajā nav nestabilu vietu.
- / Stikla satur svina oksīds.

## SŪMBOLITE KIRJELDUS



Ārge kasutage ādikhapet sisaldavat silikoonil



MŌŌTUDE (vt lk 17)

Klaas võib olla erimõõduline, kuna see on suuga puhutud. Kaebus pole õigustatud.



VARUOSAD (vt lk 23)

XXX = Värvid  
 000 = kroom  
 300 = Polished RedGold  
 310 = Brushed Red Gold  
 330 = Polished Black Chrome  
 340 = Brushed Black Chrome  
 820 = brushed nickel  
 990 = kuld optik



PUHASTAMINE (vt lk 22)

Eemaldage täitis ja puhastus pumba kate täitmiseks ja puhastamiseks.



MAHAMONTEERIMINE (vt lk 21)



Neizmantot silikonu, kas satur etiķskābil



IZMĒRUS (skat. lpp. 17)

Izpūstas stikla daļas - izmēru atšķirības nevar būt reklamācijas iemesls.



REZERVES DAĻAS (skat. lpp. 23)

XXX = Krāsu kodi  
 000 = hroma  
 300 = Polished RedGold  
 310 = Brushed Red Gold  
 330 = Polished Black Chrome  
 340 = Brushed Black Chrome  
 820 = brushed nickel  
 990 = zelta



TĪRĪŠANA (skat. lpp. 22)

Lai piepildītu un iztīrītu, noņemiet sūkni un vāciņu.



DEMONTĀŽA (skat. lpp. 21)

PAIGALDAMINE (vt lk 18)



MONTĀŽA (skat. lpp. 18)



### ⚠ SIGURNOSNE NAPOMENE

- ⚠ Prilikom montaže se radi sprečavanja prignječenja i posekotina moraju nositi rukavice.
- ⚠ Za držanje sme da se koristi isključivo drška 41730XXX, svi ostali proizvodi su za tu svrhu nepodesni.
- ⚠ Propisna pričvršćenost i stabilnost postavljenih proizvoda treba redovno da se proverava (jednom godišnje).

### INSTRUKCIJE ZA MONTAŽU

- / Kada proizvod montira kvalifikovano stručno osoblje treba paziti da čitava površina na koju se učvršćuje bude ravna (bez istaknutih fuga ili krivljenja pločica), da je zidna konstrukcija primerena montaži proizvoda i da nema slabih mesta.
- / Staklo sadrži olovo oksid.

### OPIS SIMBOLA



Nemojte koristiti silikon koji sadrži sirćetnu kiselinu!



MERE (vidi stranu 17)  
Ručno napravljeni stakleni delovi - odstupanje dimenzija ne predstavlja razlog za reklamaciju proizvoda.



REZERVNI DELOVI (vidi stranu 23)  
XXX = Oznake boja  
000 = hrom  
300 = Polished RedGold  
310 = Brushed Red Gold  
330 = Polished Black Chrome  
340 = Brushed Black Chrome  
820 = brushed nickel  
990 = dezen zlatna



ČIŠĆENJE (vidi stranu 22)  
Kod punjenja i čišćenja pumpe skinite poklopac.



RASTAVLJANJE (vidi stranu 21)

MONTAŽA (vidi stranu 18) 

### ⚠ SIKKERHETSHENVISNINGER

- ⚠ Bruk hansker under montasjen for å unngå klem- og kuttskader.
- ⚠ For å holde seg fast skal kun håndtaket brukes 41730XXX. De øvrige produktene er ikke egnet for dette bruk.
- ⚠ De monterte produktene skal regelmessig sjekkes om de er ordentlig festet og om de sitter fast.

### MONTAGEHENVISNINGER

- / Under monteringen av produktet gjort av kvalifisert fagpersonell, skal man påse at monteringsoverflaten på hele festeområdet er plant (ingen utstikkende fuger eller flisekanter), at veggoppbyggingen egner seg for produktmontasjen og ikke viser svake punkter.
- / Glasset inneholder blyoksid.

### SYMBOLBESKRIVELSE



Ikke bruk silikon som inneholder eddiksyre!



MÅL (se side 17)  
Munnblåste deler - Måldifferanser gir ingen rett til reklamasjon



SERVICEDELER (se side 23)  
XXX = Fargekode  
000 = krom  
300 = Polished RedGold  
310 = Brushed Red Gold  
330 = Polished Black Chrome  
340 = Brushed Black Chrome  
820 = børstet nikkell  
990 = gull-optikk



RENGJØRING (se side 22)  
Ta av deksel og pumpe for fylling og rengjøring.



DEMONTASJE (se side 21)

MONTASJE (se side 18) 

## ▲ УКАЗАНИЯ ЗА БЕЗОПАСНОСТ

- ▲ При монтажа трябва да се носят ръкавици, за да се избегнат наранявания поради притискане или порязване.
- ▲ За хващане да се използва само дръжката 41730XXX, останалите продукти не са подходящи за тази цел.
- ▲ Правилното закрепване и правилното разположение на монтираните продукти трябва да се проверява периодично (ежегодно).

## УКАЗАНИЯ ЗА МОНТАЖ

- / При монтаж на продукта от квалифицирани специалисти да се внимава за това, закрепващата повърхност в целия диапазон на закрепването да бъде равна (без изпъкнали фуги или изместване на плочки), конструкцията на стената да е подходяща за монтаж на продукта и да няма слаби места.
- / Стъклото съдържа оловен оксид.

## ОПИСАНИЕ НА СИМВОЛИТЕ



Не използвайте силикон, съдържащ оцетна киселина!



РАЗМЕРИ (вижте стр. 17)

Ръчно духани части - Отклоненията от размерите не могат да бъдат повод за рекламация.



СЕРВИЗНИ ЧАСТИ (вижте стр. 23)

XXX = Цветово кодиране  
 000 = хром  
 300 = Polished RedGold  
 310 = Brushed Red Gold  
 330 = Polished Black Chrome  
 340 = Brushed Black Chrome  
 820 = надраскан никел  
 990 = оптика на злато



ПОЧИСТВАНЕ (вижте стр. 22)

За пълнене и почистване свалете помпата и капака.



ДЕМОНТАЖ (вижте стр. 21)

## ▲ UDHËZIME SIGURIE

- ▲ Për të evituar lëndimet e pickimeve ose të prerjeve gjatë procesit të montimit duhet që të vishni doreza.
- ▲ Vetëm doreza 41730XXX mund të përdoret për t'u mbajtur. Të gjitha produktet e tjera nuk janë të përshtatshme për këtë qëllim.
- ▲ Montimi dhe pozicioni sipas rregullave i produkteve të montuara duhet verifikuar periodikisht (një herë në vit).

## UDHËZIME PËR MONTIMIN

- / Gjatë montimit të produktit nga teknikët e specializuar duhet mbajtur parasysh që sipërfaqja e montimit gjendet brenda zonës së përgjithshme të planit të montimit (nuk ka vendbashkime të dala ose mospërputhje të pllakave), që struktura e murit është e përshtatshme për montimin e produktit dhe që nuk paraqet asnjë pikë të dobët.
- / Xhami përmban oksid plumbi.

## PËRSHKRIMI I SIMBOLIT



Mos përdorni silikon që në përbërje ka acid acetik.



PËRMASAT (shih faqen 17)

Pjesë të fryra me gojë - devijime nga përmasat nuk ju japin të drejtën të bëni reklamacion



PJESËT E SERVISIT (shih faqen 23)

XXX = Kodimi me anë të ngjyrave  
 000 = krom  
 300 = Polished RedGold  
 310 = Brushed Red Gold  
 330 = Polished Black Chrome  
 340 = Brushed Black Chrome  
 820 = nikel i furçuar  
 990 = optikë e artë



PASTRIMI (shih faqen 22)

Për mbushje dhe pastrim të hiqen pompa dhe kapaku.



ÇMONTIMI (shih faqen 21)

МОНТАЖ (вижте стр. 18) 

МОНТИМИ (shih faqen 18) 

### ⚠ تنبيهات الأمان

⚠ يجب إرتداء قفازات اليد أثناء التركيب لتجنب حدوث أخطار الإنحشار أو الجروح.

⚠ يحظر استخدام المقبض إلا من أجل التثبيت فحسب 41730XXX. وبالنسبة لبقية المنتجات الأخرى، فهي غير صالحة لهذا الغرض من الاستخدام.

⚠ يتعين التأكد من أن حالة التثبيت مطابقة للشروط المحددة والتأكد من الوضع الثابت للمنتجات المركبة على فترات منتظمة (سنوياً)

### تعليمات التركيب

/ عند التركيب بواسطة عمال تركيب متخصصين يجب الإنتباه إلى أن مساحة التثبيت في مكان التركيب بوجه عام مسطحة (لا توجد روابط أو فروق للربط بين البلاطات). لذا يجب التأكد من أن الحائط الذي سيتم تركيب المنتج عليه صالح لذلك وأنه لا يوجد به نقاط ضعف.

/ يحتوي الزجاج أكسيد الرصاص.

### وصف الرمز

هام! لا تستخدم السليكون الذي يحتوي على أحماض!



أبعاد (راجع صفحة 17)  
قد يسبب البخار المتراكم على القطع تغييراً في الأبعاد الحقيقية، ولذلك فإنه لا يلزم المطالبة بتوصليحات.



قطع الغيار (راجع صفحة 23)



XXX = الألوان

000 = كروم

Polished RedGold = 300

Brushed Red Gold = 310

Polished Black Chrome = 330

Brushed Black Chrome = 340

820 = نيكل مُفَرَش

990 = لون ذهبي

التنظيف (راجع صفحة 22)  
ارفع المضخة والغطاء للملء والتنظيف.



فك التركيب (راجع صفحة 21)



التركيب (راجع صفحة 18)







41528XXX

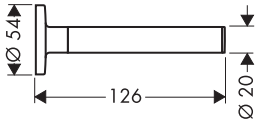

41721XXX



41735XXX

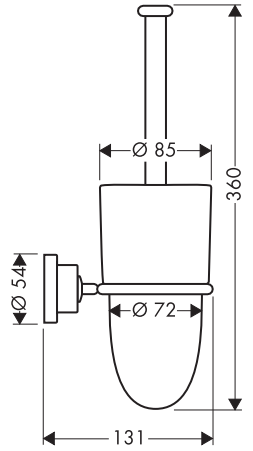

41734XXX

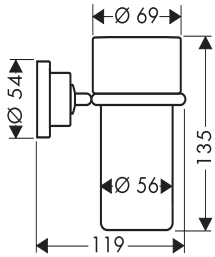

41733XXX

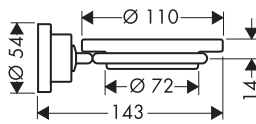

41719XXX

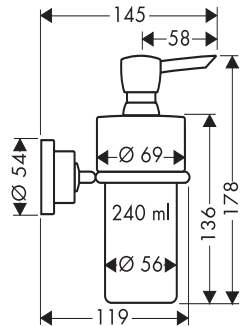

41738XXX

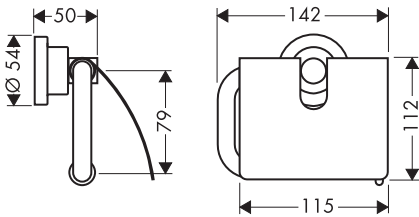

41760XXX

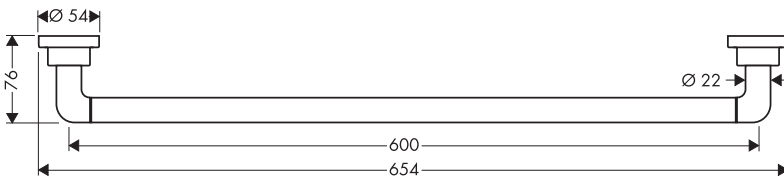

41780XXX

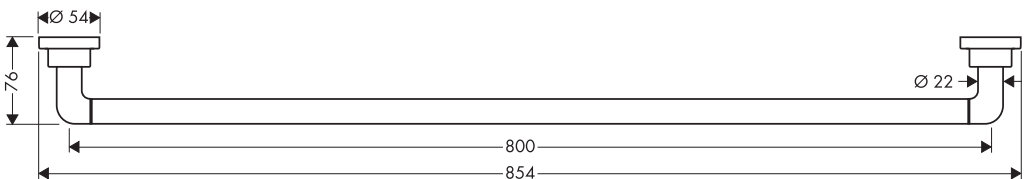

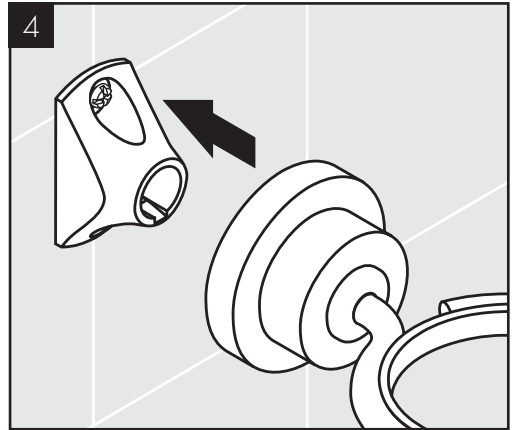
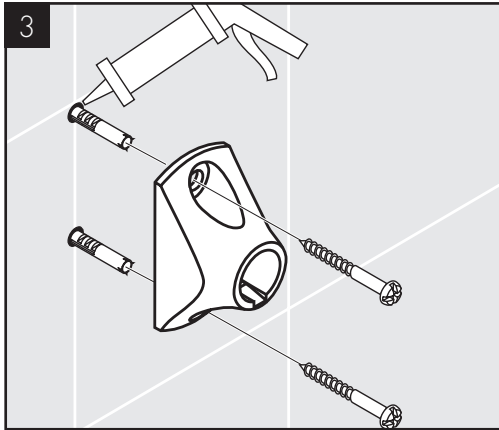
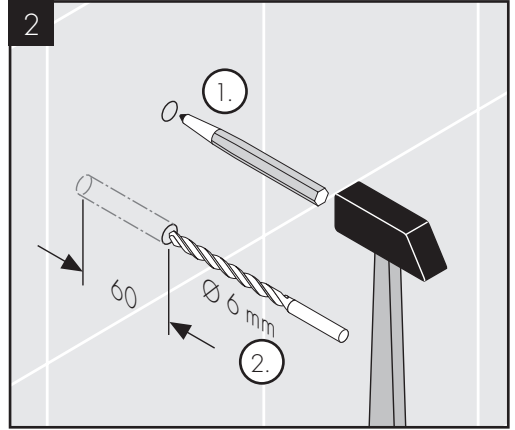
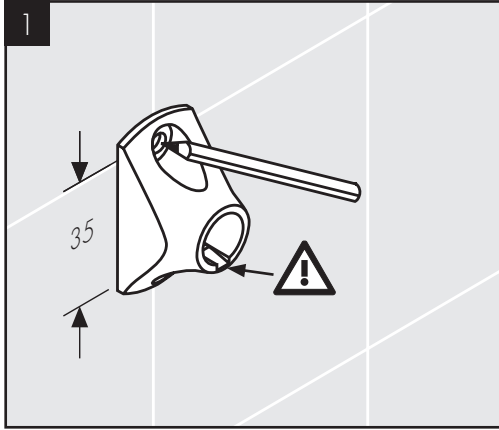



41528XXX

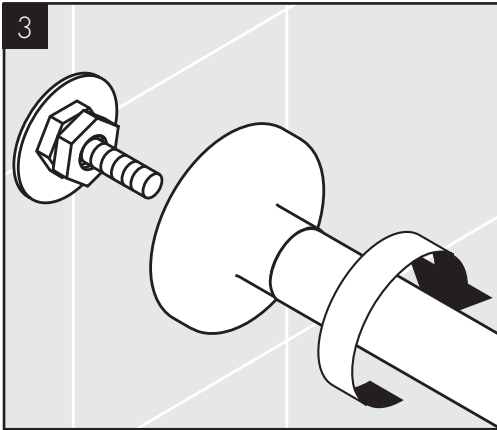
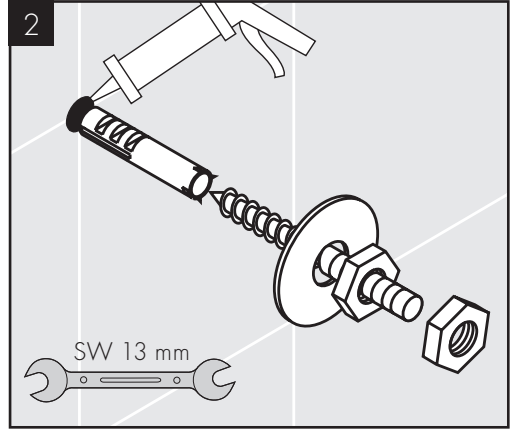
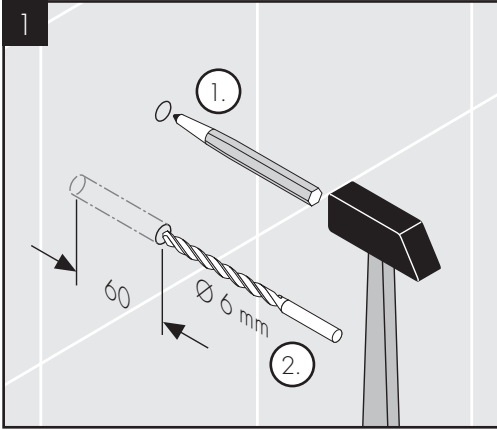

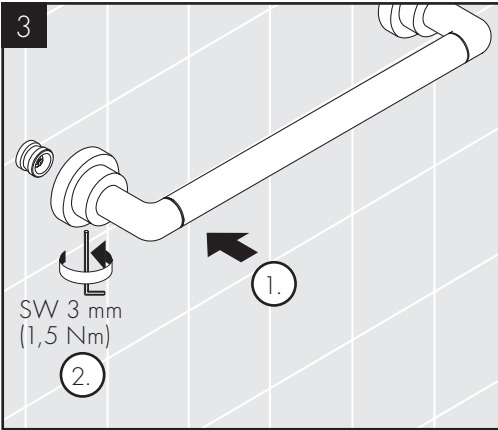
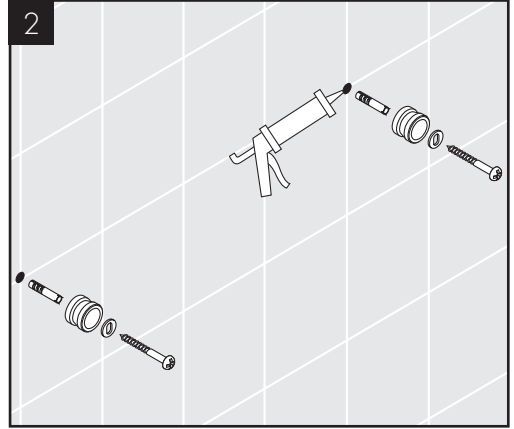
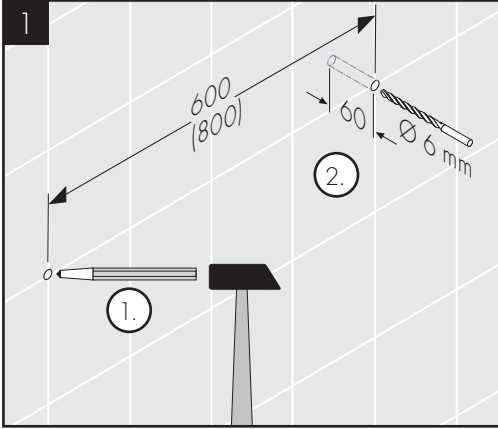

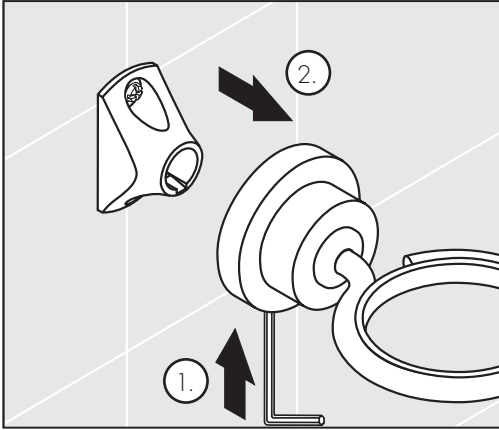



- DE / Reinigungsempfehlung / Garantie / Kontakt  
 FR / Recommandation pour le nettoyage / Garanties / Contact  
 EN / Cleaning recommendation / Warranty / Contact  
 IT / Raccomandazione di pulizia / Garanzia / Contatto  
 ES / Recomendaciones para la limpieza / Garantía / Contacto  
 NL / Aanbevelingen inzake reiniging / Garantie / Contact  
 DK / Rensning, anbefaling / Garanti / Kontakt  
 PT / Recomendações de limpeza / Garantia / Contacto  
 PL / Zalecenie dotyczące pielęgnacji / Gwarancja / Kontakt  
 CS / Doporučení k čištění / Záruka / Kontakt  
 SK / Odporúčania pre čistenie / Záruka / Kontakt  
 ZH / 清洁指南 / 担保 / 接触  
 RU / Рекомендации по очистке / Гарантия / Контакты  
 HU / Tisztítási tanácsok / Garancia / érintkezés  
 FI / Puhdistussuositus / Takuu / Kosketus  
 SV / Rengöringsrekommendationer / Garanti / Contacto  
 LT / Valymo rekomendacijos / Garantija / Kontaktai  
 HR / Preporuke za čišćenje / Garancija / Kontakt  
 TR / Temizleme önerisi / Garanti / Temas  
 RO / Recomandări pentru curățare / Garanție / Contact  
 EL / Σύσταση καθαρισμού / Εγγύηση / επαφή  
 SL / Priporočilo za čišćenje / Garancija / Kontakt  
 ET / Puhastussuovitused / Garantii / Kontakt  
 LV / Tīrīšanas ieteikumi / Garantija / Kontakti  
 SR / Preporuke za čišćenje / Garancija / Kontakt  
 NO / Anbefaling for rengjøring / Garanti / Kontakt  
 BG / Препоръка за почистване / Гаранция / Контакт  
 SQ / Këshilla rreth pastrimit / Garancia / Kontakt  
 KO / 세정시 권장사항 / 품질보증 / 접촉  
 AR / توصيات التنظيف / الضمان (الولايات المتحدة الأمريكية) / اتصال

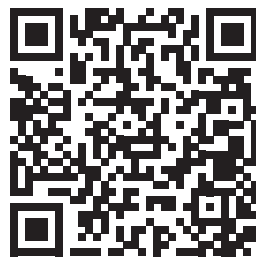

[www.axor-design.com/  
cleaning-recommendation](http://www.axor-design.com/cleaning-recommendation)

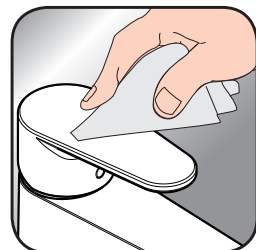

[www.axor-design.com/  
cleaning-recommendation](http://www.axor-design.com/cleaning-recommendation)



[www.axor-design.com/  
cleaning-recommendation](http://www.axor-design.com/cleaning-recommendation)

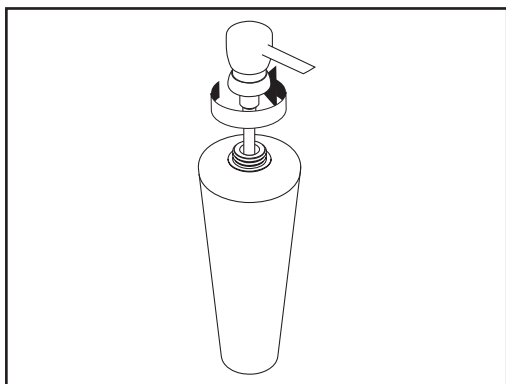

[www.axor-design.com/  
cleaning-recommendation](http://www.axor-design.com/cleaning-recommendation)

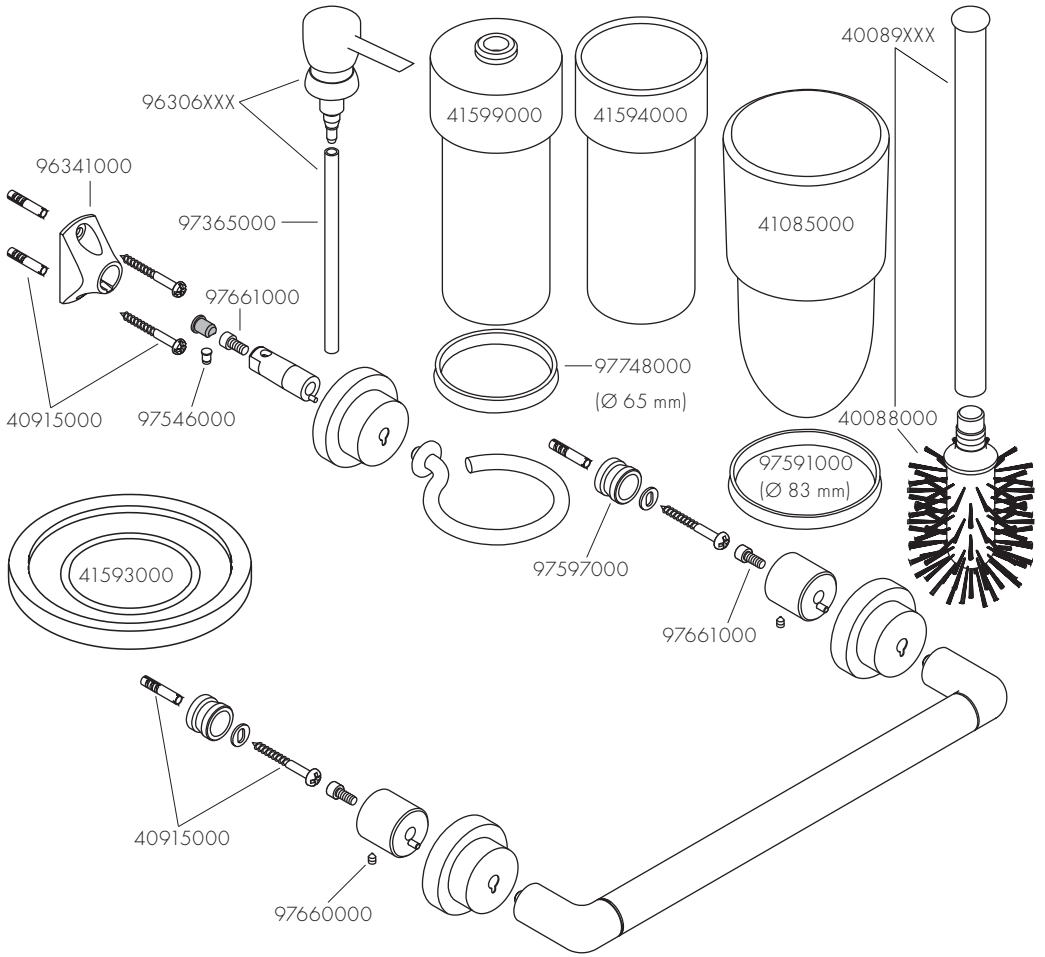

# AXOR

AXOR / Hansgrohe SE  
Austraße 5-9  
77761 Schiltach  
Deutschland

[info@axor-design.com](mailto:info@axor-design.com)  
[axor-design.com](http://axor-design.com)

11/2018  
9.09753.04