



ACTIVE

EN	Installation and service manual	Kitchen Faucet
DE	Installations- und Serviceanleitung	Küchenmischer
FR	Manuel d'installation et d'entretien	Robinet de cuisine
NL	Installatie- en onderhoudshandleiding	Keukenkraan
IT	Manuale per l'installazione e il servizio di assistenza	Rubinetto cucina
ES	Manual de instalación y servicio	Grifo de cocina
PT	Manual de instalação e de assistência	Misturadora de cozinha
EL	Εγκατάσταση και εγχειρίδιο συντήρησης	Μπαταρία κουζίνας
DA	Installations- og servicevejledning	Køkkenblandingsbatteri
NO	Installasjons- og servicemanual	Kjøkkenkran
SV	Installations- och servicehandbok	Köksblandare
FI	Asennus- ja huolto-ohje	Keittiöhana
LT	Montavimo ir techninė priežiūra	Virtuvinis maišytuvas
LV	Uzstādīšanas un apkopes rokasgrāmata	Virtuves jaucējkrāns
ET	Paigaldus- ja hooldusjuhend	Köögikraan
CS	Montážní a servisní návod	Kuchyňská baterie
PL	Instrukcja montażu i serwisowania	Bateria kuchenna
SK	Návod na inštaláciu a obsluhu	Kuchynský kohútik
SL	Priročnik za namestitvev in servisiranje	Kuhinjska pipa
SR	Priručnik za instalaciju i servisiranje	Kuhinjska slavina
HU	Szerelési és szerviz útmutató	Mosogató csaptelep
HR	Priručnik za instalaciju i servis	Kuhinjska slavina
RO	Manual de instalare și service	Robinet de bucătărie
BG	Ръководство за монтаж и обслужване	Кухненски кран
UK	Посібник зі встановлення та обслуговування	Кухонні змішувачі
RU	Руководство по установке и обслуживанию	Кухонный смеситель
TR	Kurulum ve servis kılavuzu	Mutfak Musluğu
ZH	安裝和維修手冊	厨房龙头
AR	ليل التركيب والخدمة	صنبور المطبخ

FRANKE



Swivel spout L shape

A

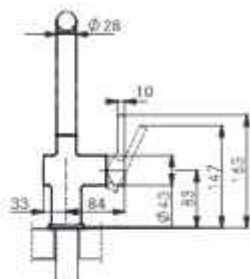
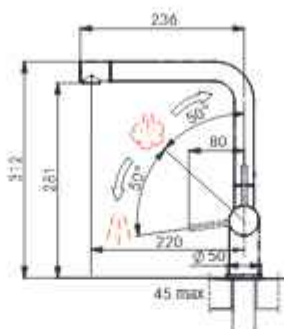

B

Swivel spout J shape

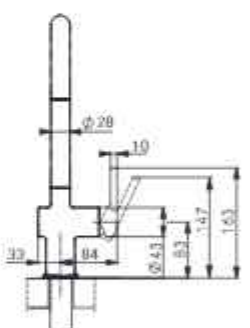
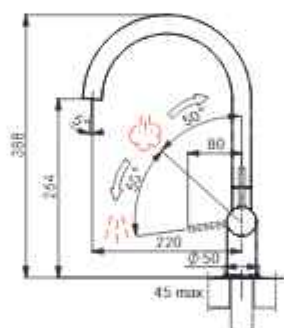

C

Semi-pro 2 jets

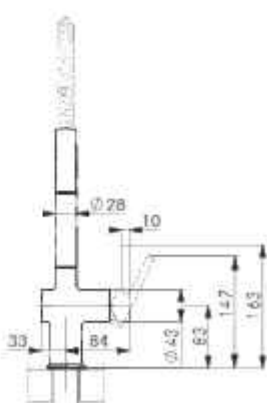
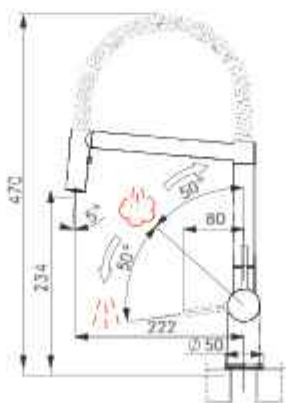

D Pull - out L shape 2 jets

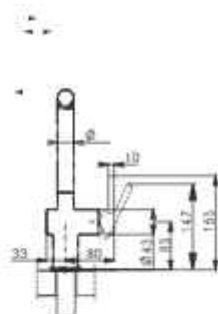
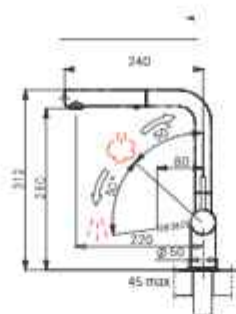

E Pull - down J shape 2 jets

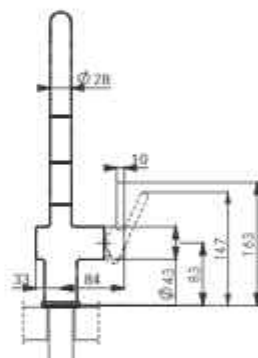
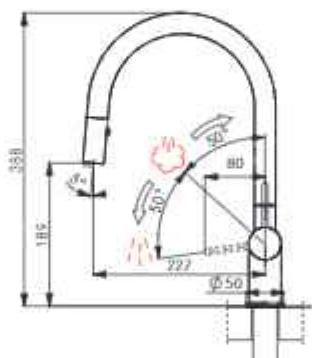

F Window Swivel spout

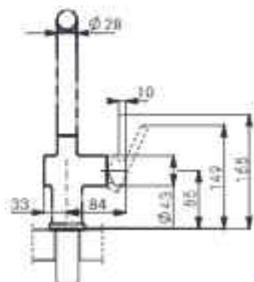
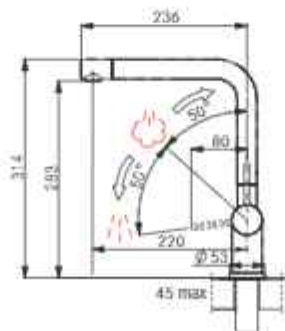

G Window pull-out 2 jets

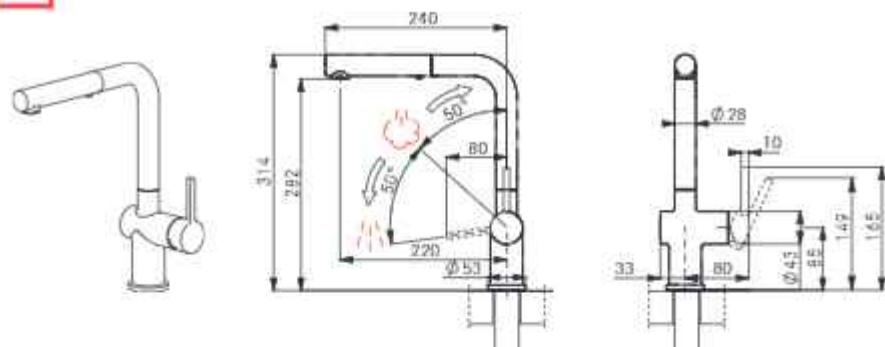

H Window Swivel spout LP

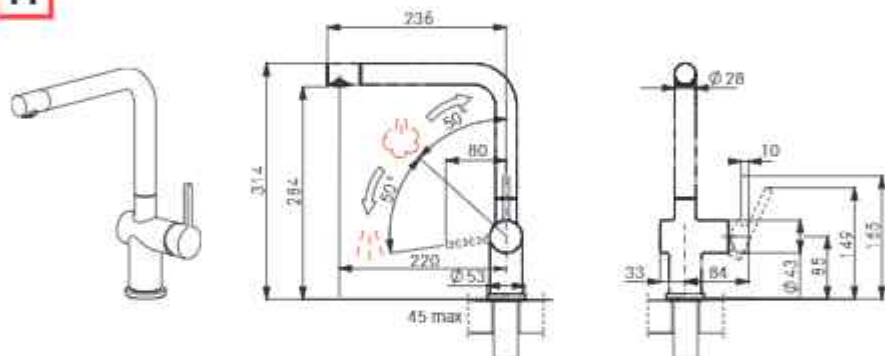

I Window pull-out 1 jet LP

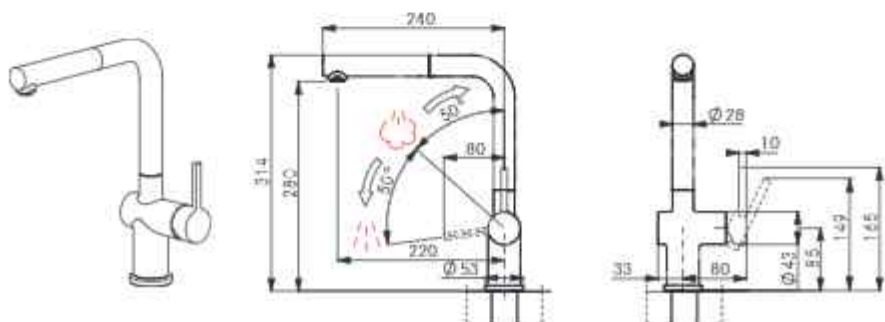

J Pull - out L shape 1 jet

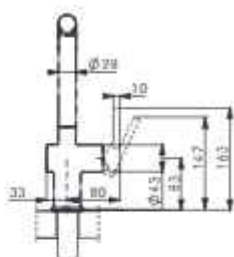
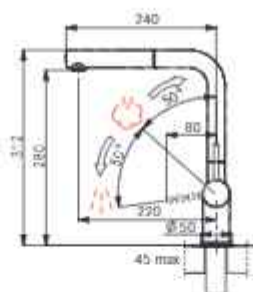

i 1 **C**



2



i 1 **D**



2



i 1 **E**



2



i **1** **G**



2



i **F** **H**

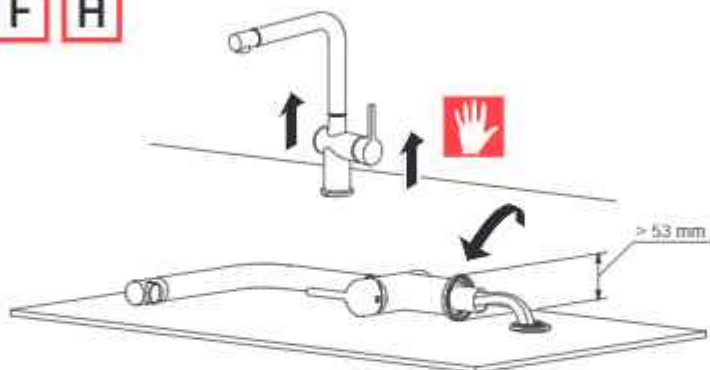

i **G** **I**

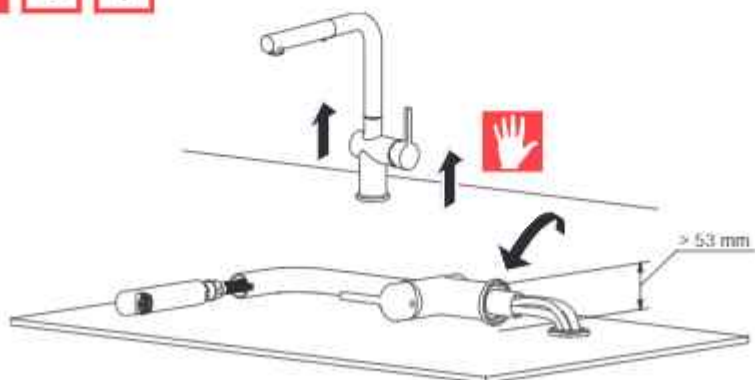



1

A

B

C

F

2



ø 35 mm max

45 mm max

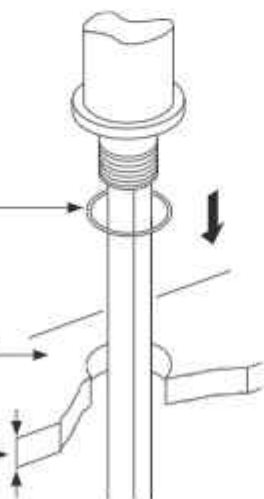

37 mm

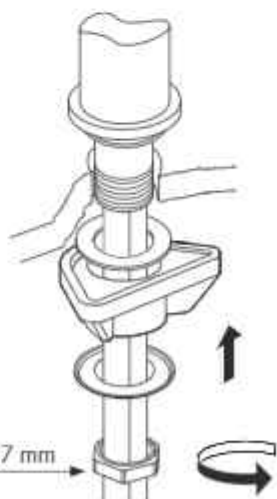

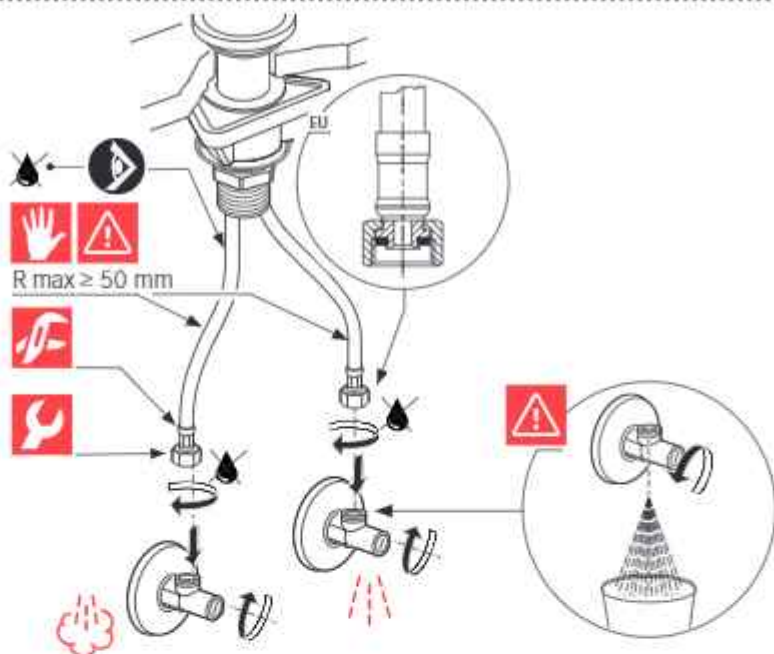
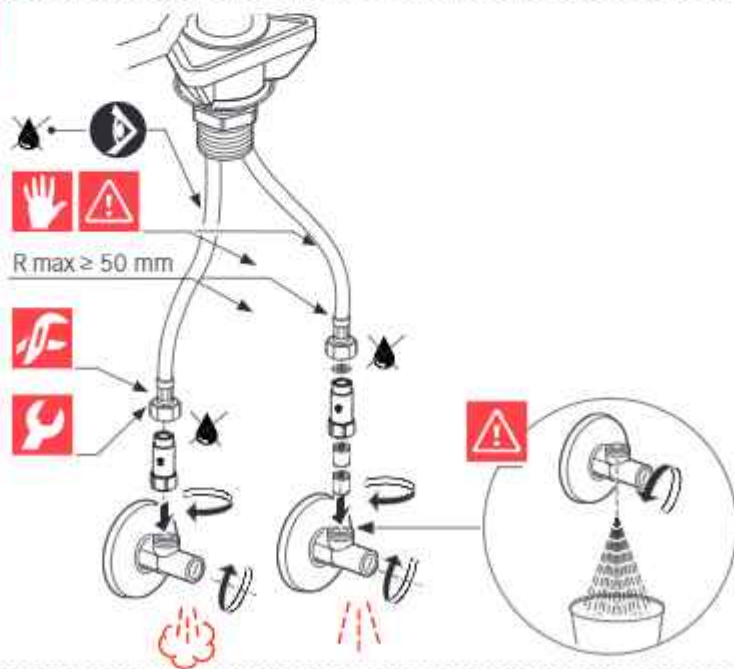
3**3****F**

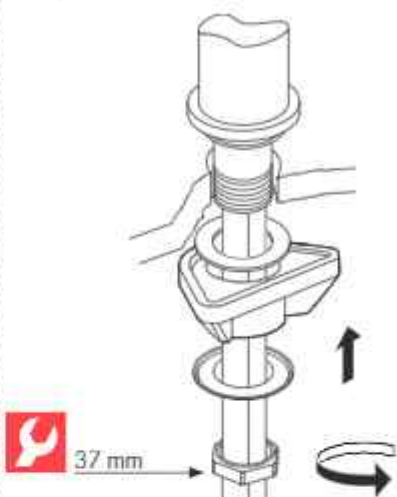
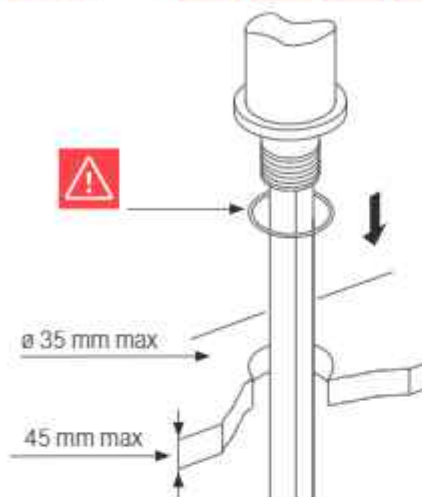
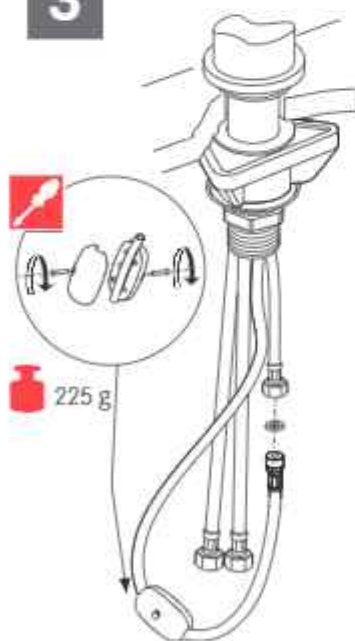
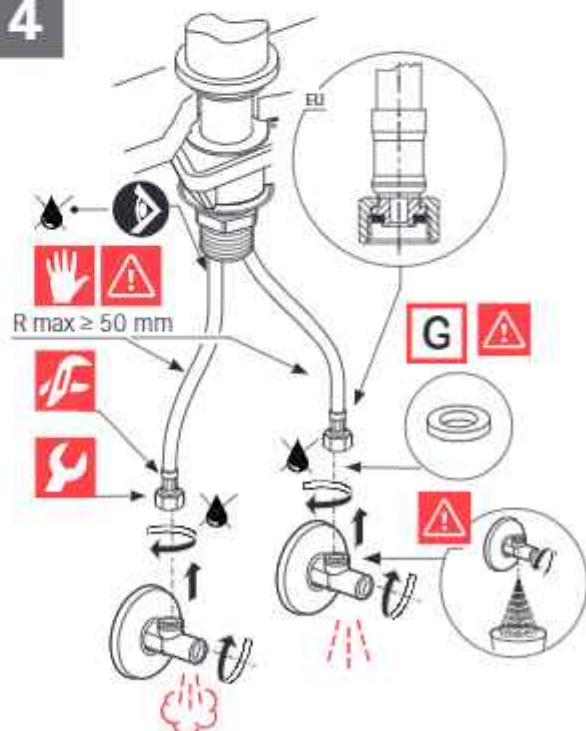
**1****D****E****G****J****2****3****4**

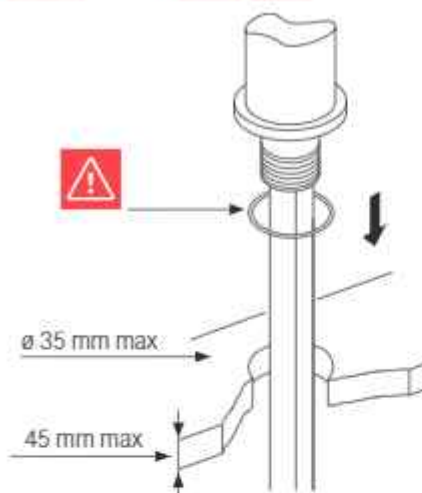
**1****H I****2**

37 mm

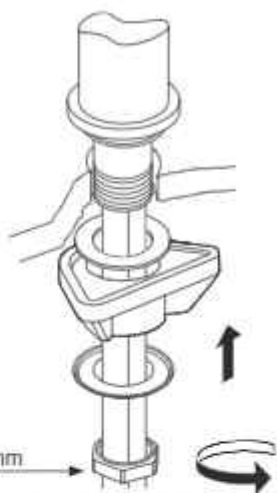
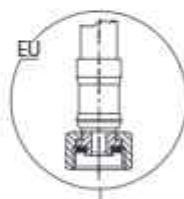
**3****H**

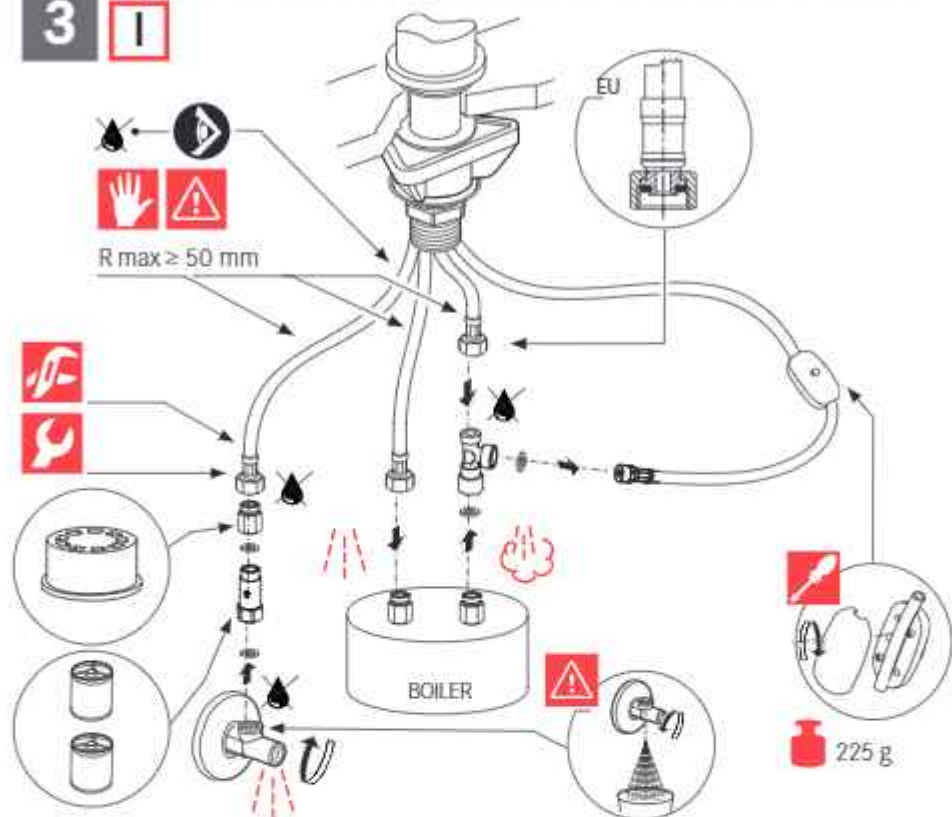
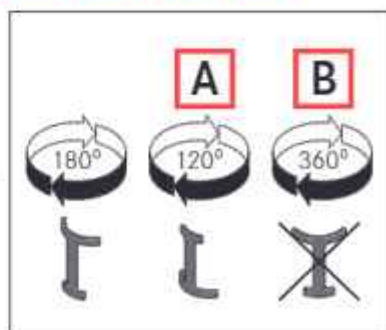
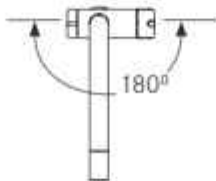
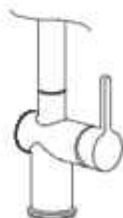
3**I****i****A****B****C****D****E****F****G****H****I****J**

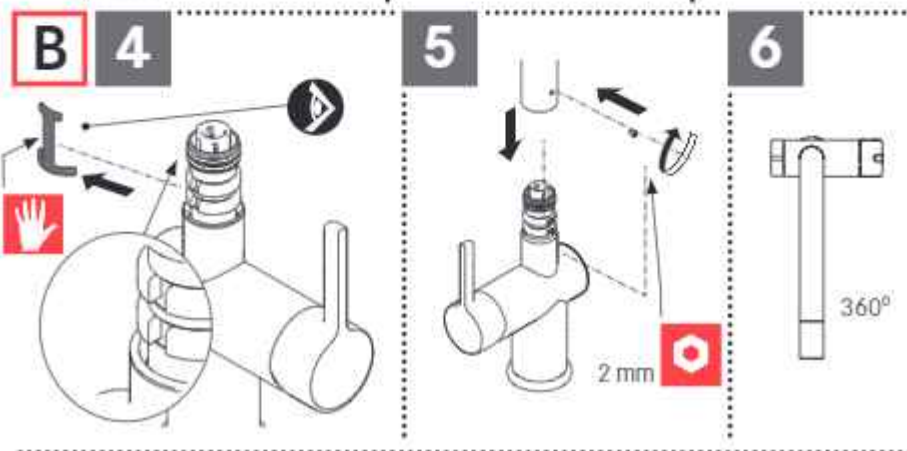
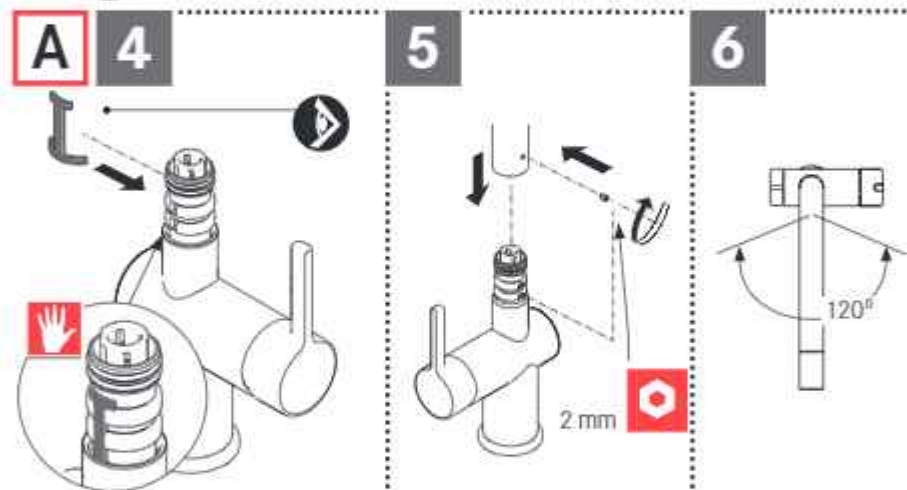
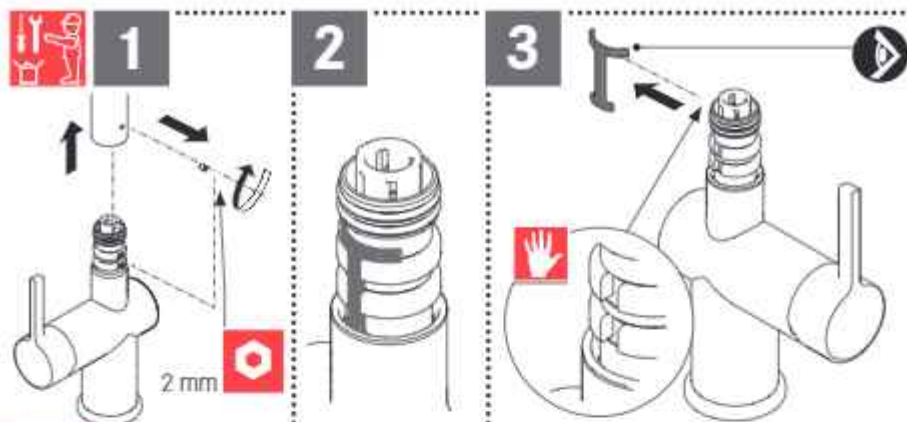

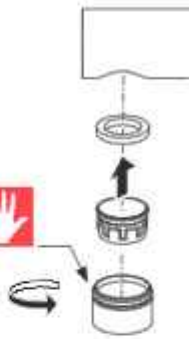
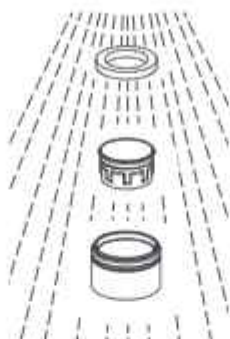
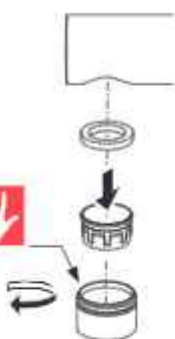
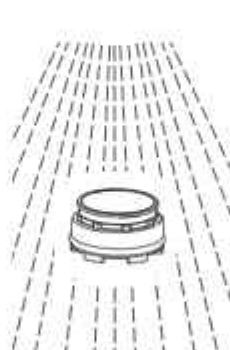
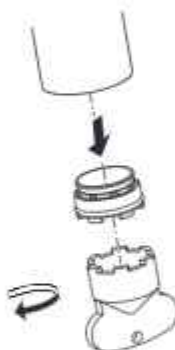
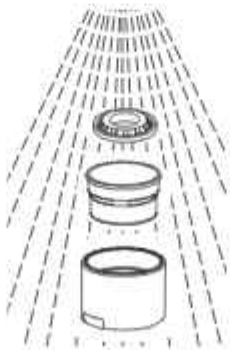
**1****A****F****2****A****F****3****A****F****1****B****2****B****3****B****1****D****G****2****D****G****3****D****G**

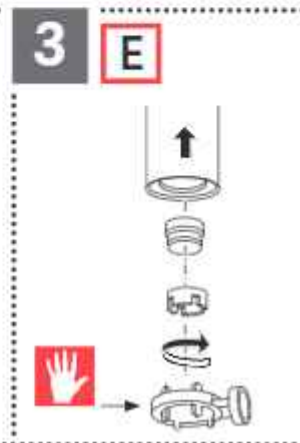
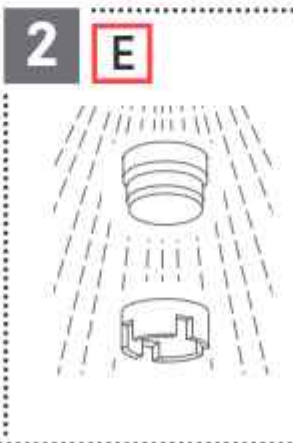
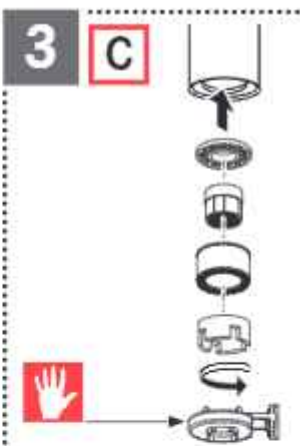
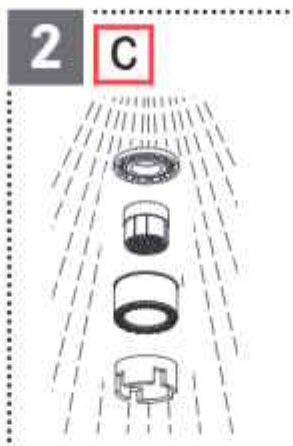
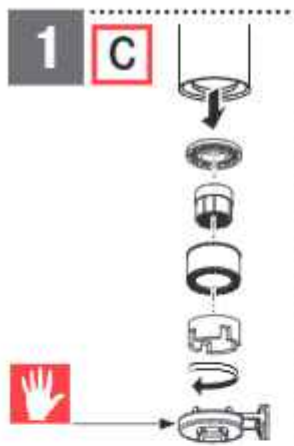

i **C** **D** **E** **G**

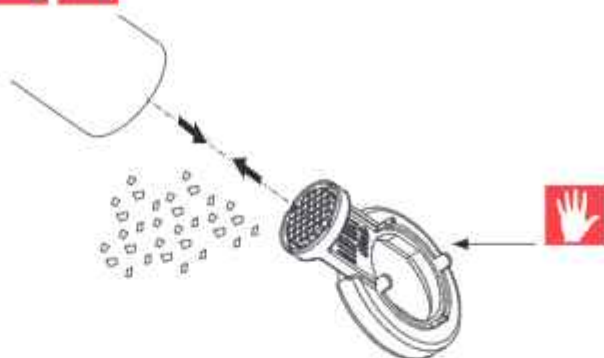

A **B** **C** **D** **E** **F** **G** **H** **I** **J**



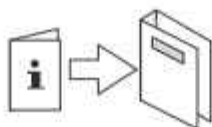
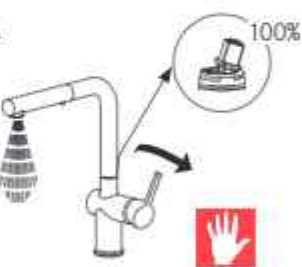
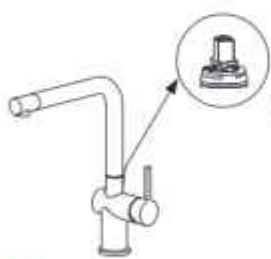
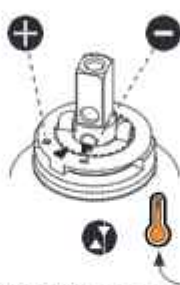
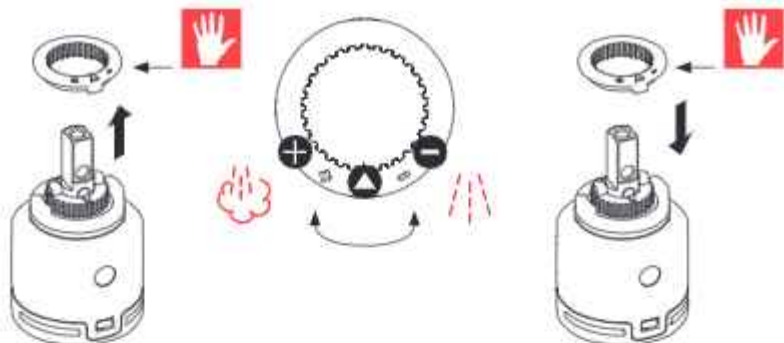

www.franke.com



Periodic checks

- ▶ Check connection and shower hoses periodically for the following:
 - Watertightness
 - Corrosion
 - Mechanical damage
- ▶ Use original spare parts only.
- ▶ Replace damp or dripping hoses.
- ▶ Replace hoses with rusty or oxidized surfaces.
- ▶ Replace hoses that show signs of mechanical damage.

Replacement of the flexibles

- ▶ Don't use a wrench or other items to mount the flexibles on the tap side. Mount these only by hand.



- ▶ Flush all pipes thoroughly before installation.

Operating data	Value		
Operating pressure (ideal)	3 bar	45 PSI	300 kPa
Operating pressure (max.)*	5 bar	70 PSI	500 kPa
Operating pressure (min.)*	1 bar	14.5 PSI	100 kPa
Water temperature (ideal)	60 °C	140 °F	
Water temperature (max.)	70 °C	158 °F	

* Equal pressure is recommended.



Regelmäßige Kontrolle

- ▶ Die Anschluss- und Brausenschläuche periodisch auf folgende Punkte kontrollieren:
 - Dichtheit
 - Korrosionsschäden
 - Mechanische Beschädigung
- ▶ Nur Originalersatzteile verwenden.
- ▶ Feuchte oder tropfende Schläuche ersetzen.
- ▶ Schläuche mit rostiger oder oxidierte Oberfläche ersetzen.
- ▶ Schläuche, die eine mechanische Beschädigung aufweisen, ersetzen.

Austausch der Schläuche

- ▶ Zur Montage der Schläuche am Wasserhahn keine Schlüssel oder andere Werkzeuge verwenden. Nur per Hand montieren.



- ▶ Vor der Montage: Alle Leitungen gründlich spülen.

Betriebsdaten	Wert
Betriebsdruck (ideal)	3 bar
Betriebsdruck (max.)*	5 bar
Betriebsdruck (min.)*	1 bar
Wassertemperatur (ideal)	60 °C
Wassertemperatur (max.)	70 °C

* Druckgleichheit empfehlenswert

FR



Contrôles périodiques

- ▶ Contrôler les flexibles de raccordement et de douche périodiquement sur les points suivants :
 - étanchéité à l'eau
 - corrosion
 - dommage mécanique
- ▶ Utilisez exclusivement des pièces détachées d'origine.
- ▶ Remplacez les flexibles humides ou qui gouttent.
- ▶ Remplacez les flexibles présentant des surfaces rouillées ou oxydées.
- ▶ Remplacez les flexibles qui montrent des signes de dommage mécanique.

Remplacement des tuyaux souples

- ▶ Ne pas utiliser de clé ou d'autre outil pour monter les tuyaux souples côté robinet. Monter les tuyaux souples à la main uniquement.



- ▶ Rincer tous les tuyaux à fond avant l'installation.

Données de fonctionnement	Valeur
Pression de service (idéale)	3 bars
Pression de service (max.)*	5 bars
Pression de service (min.)*	1 bar
Température de l'eau (idéale)	60 °C
Température de l'eau (max.)	70 °C

* Une pression constante est conseillée.



Periodieke controles

- ▶ Controleer regelmatig de aansluit- en doucheslangen op het volgende:
 - Waterdichtheid
 - Corrosie
 - Mechanische schade
- ▶ Gebruik uitsluitend originele onderdelen.
- ▶ Vervang vochtige of druipende slangen.
- ▶ Vervang slangen met roestige of geoxideerde oppervlakken.
- ▶ Vervang slangen die mechanische schade vertonen.

Vervanging van de flexibele slangen

- ▶ Gebruik geen sleutel of andere hulpmiddelen om de slangen aan de kraanzijde te monteren. Monteer ze uitsluitend met de hand.



- ▶ Spoel alle slangen vóór het installeren zorgvuldig door.

Werkingsgegevens	Waarde
Bedrijfsdruk (ideaal)	3 bar
Bedrijfsdruk (max.)*	5 bar
Bedrijfsdruk (min.)*	1 bar
Watertemperatuur (ideaal)	60 °C
Watertemperatuur (max.)	70 °C

* gelijke druk aanbevolen.



Controlli periodici

- ▶ Effettuare periodicamente i seguenti controlli sui flessibili di collegamento e sul flessibile della doccia:
 - Tenuta stagna
 - Corrosione
 - Danni meccanici
- ▶ Utilizzare solo parti di ricambio originali.
- ▶ Sostituire i flessibili che risultano umidi o gocciolano.
- ▶ Sostituire i flessibili che presentano superfici arrugginite o ossidate.
- ▶ Sostituire i flessibili che presentano segni di danni meccanici.

Sostituzione dei raccordi flessibili

- ▶ Non usare chiavi o altri strumenti per montare i raccordi flessibili sul lato del rubinetto. Montarli esclusivamente a mano.



- Far scorrere abbondante acqua in tutti i tubi prima dell'installazione.

Dati di funzionamento	Valore
Pressione di funzionamento (ideale)	3 bar
Pressione di funzionamento (max)*	5 bar
Pressione di funzionamento (min)*	1 bar
Temperatura acqua (ideale)	60 °C
Temperatura acqua (max)	70 °C

* Si consiglia una pressione uniforme.

ES



Comprobaciones periódicas

- En los caños de ducha y los latiguillos de conexión, compruebe periódicamente lo siguiente:
 - Estanqueidad
 - Corrosión
 - Daño mecánico
- Use exclusivamente recambios originales.
- Si los latiguillos o caños están húmedos o gotean, sustitúyalos.
- Si los latiguillos o caños presentan zonas oxidadas o herrumbrosas, sustitúyalos.
- Si los latiguillos o caños presentan signos de daño mecánico, sustitúyalos.

Sustitución de los elementos flexibles

- No utilizar llaves ni otro tipo de herramientas para fijar los elementos flexibles en el lado del grifo. Fijarlos solamente a mano.



- Enjuague a fondo todos los tubos antes de proceder con la instalación.

Datos de funcionamiento	Valor		
Presión de funcionamiento (ideal)	3 bares	45 PSI	300 kPa
Presión de funcionamiento (máx.)*	5 bares	70 PSI	500 kPa
Presión de funcionamiento (mín.)*	1 bar	14,5 PSI	100 kPa
Temperatura del agua (ideal)	60 °C	140 °F	
Temperatura del agua (máx.)	70 °C	158 °F	

* Se recomienda una presión homogénea.



Verificações periódicas

- ▶ Verifique os tubos de ligação e do chuveiro periodicamente quanto ao seguinte:
 - Estanqueidade à água
 - Corrosão
 - Danos mecânicos
- ▶ Utilize apenas peças sobresselentes originais.
- ▶ Substitua os tubos que estejam húmidos ou a pingar.
- ▶ Substitua os tubos com superfícies ferrugentas ou oxidadas.
- ▶ Substitua os tubos que mostrem sinais de danos mecânicos.

Substituição dos flexíveis

- ▶ Não use uma chave de fenda ou outros itens para montar os flexíveis no lado da torneira. Monte usando somente as mãos.



- ▶ Lave bem todos os tubos antes da instalação.

Dados de operação	Valor		
Pressão de operação (ideal)	3 bar	45 PSI	300 kPa
Pressão de operação (máx.)*	5 bar	70 PSI	500 kPa
Pressão de operação (mín.)*	1 bar	14,5 PSI	100 kPa
Temperatura da água (ideal)	60 °C	140 °F	
Temperatura da água (máx.)	70 °C	158 °F	

* É recomendada uma pressão igual.



Περιοδικοί έλεγχοι

- ▶ Ελέγχετε τακτικά τις υδραυλικές συνδέσεις και τον εύκαμπο σωλήνα του ντους για τα ακόλουθα:
 - Στεγανότητα
 - Διάβρωση
 - Μηχανική βλάβη
- ▶ Χρησιμοποιείτε μόνο αυθεντικά ανταλλακτικά.
- ▶ Αντικαταστήστε σωλήνες με υγρασία ή σταγονίδια.
- ▶ Αντικαταστήστε σωλήνες με σκουριασμένες ή οξειδωμένες επιφάνειες.
- ▶ Αντικαταστήστε σωλήνες που παρουσιάζουν σημάδια μηχανικής βλάβης.

Αντικατάσταση των εύκαμπων σωλήνων

- ▶ Μην χρησιμοποιείτε γαλλικό κλειδί ή άλλα εργαλεία για την τοποθέτηση των εύκαμπων σωλήνων στην πλευρά της βρύσης. Τοποθετήστε τους μόνο με το χέρι.



- Ρίξτε άφθονο νερό στους σωλήνες πριν την εγκατάσταση.

Δεδομένα λειτουργίας	Τιμή		
Πίεση λειτουργίας (ιδανικά)	3 bar	45 PSI	300 kPa
Πίεση λειτουργίας (μέγ.)*	5 bar	70 PSI	500 kPa
Πίεση λειτουργίας (ελάχ.)*	1 bar	14,5 PSI	100 kPa
Θερμοκρασία νερού (ιδανικά)	60 °C	140 °F	
Θερμοκρασία νερού (μέγ.)	70 °C	158 °F	

* Συστήνεται όμοια πίεση.

DA



Periodisk kontrol

- Undersøg forbindelse og bruseslanger periodisk for følgende:
 - Vandtæthed
 - Tæring
 - Mekanisk skade
- Brug udelukkende originale reservedele.
- Udskift fugtige eller dryppende slanger.
- Udskift slanger med rustbelagte eller oxiderede overflader.
- Udskift slanger med tegn på mekanisk skade.

Udskiftning af forbindelser

- Brug ikke en skrueøgle eller andre genstande til at montere forbindelserne på tappesiden. Monter kun disse med hånden.



- Skyl alle rør grundigt igennem før installation.

Driftsdata	Værdi		
Driftstryk (ideelt)	3 bar	45 PSI	300 kPa
Driftstryk (maks.)*	5 bar	70 PSI	500 kPa
Driftstryk (min.)*	1 bar	14,5 PSI	100 kPa
Vandtemperatur (ideel)	60 °C	140 °F	
Vandtemperatur (maks.)	70 °C	158 °F	

* Ens tryk anbefales.



Jevnlige kontroller

- ▶ Kontroller koblinger og dusjslanger jevnlig for følgende:
 - Vanntetthet
 - Korrosjon
 - Mekanisk skade
- ▶ Bare bruk originale reservedeler.
- ▶ Skift ut fuktige eller dryppende slanger.
- ▶ Skift ut slanger med rustne eller oksiderte overflater.
- ▶ Skift ut slanger som viser tegn på mekanisk skade.

Utskiftning av utstyret

- ▶ Ikke bruk skiftenøkkel eller andre gjenstander for å montere utstyret på tappesiden. Dette skal bare monteres for hånd.



- ▶ Skyll grundig gjennom alle rør før installasjon.

Driftsdata	Verdi		
Driftstrykk (ideelt)	3 bar	45 PSI	300 kPa
Driftstrykk (maks.)*	5 bar	70 PSI	500 kPa
Driftstrykk (min.)*	1 bar	14,5 PSI	100 kPa
Vanntemperatur (ideell)	60 °C	140 °F	
Vanntemperatur (maks.)	70 °C	158 °F	

* Likt trykk anbefales.



Regelbundna kontroller

- ▶ Kontrollera regelbundet anslutningen och duschslangarna med avseende på följande:
 - Vattentätthet
 - Korrosion
 - Mekanisk skada
- ▶ Använd endast originalreservdelar.
- ▶ Byt ut fuktiga eller droppande slangar.
- ▶ Byt ut slangar med rostiga eller oxiderade ytor.
- ▶ Byt ut slangar som visar tecken på mekanisk skada.

Utbyte av flexibla slangar

- ▶ Använd inte en skiftnyckel eller andra föremål för att montera slangar på kranens sida. Montera endast dessa för hand.



- Spola grundligt alla rör före installation.

Driftdata	Värde		
Driftstryck (idealiskt)	3 bar	45 PSI	300 kPa
Driftstryck (max.)*	5 bar	70 PSI	500 kPa
Driftstryck (min.)*	1 bar	14,5 PSI	100 kPa
Vattentemperatur (idealisk)	60 °C	140 °F	
Vattentemperatur (max.)	70 °C	158 °F	

* Lika tryck rekommenderas.

FI



Määräaikaistarkastukset

- Tarkasta liitokset ja suihkuletkut säännöllisesti seuraavien seikkojen varalta:
 - Vesitiivisyys
 - Korroosio
 - Mekaaniset vauriot
- Käytä vain alkuperäisiä varaosia.
- Vaihda kosteat tai valuvat letkut uusiin.
- Vaihda letkut, joiden pinta on ruosteessa tai hapettunut.
- Vaihda letkut, joissa näkyy mekaanisia vaurioita.

Letkujen vaihtaminen

- Älä käytä jakoavainta tai muita vastaavia asentaessasi letkuja hanan sivuun. Asenna ne ainoastaan käsin.



- Huuhtelee kaikki putket huolellisesti ennen asennusta.

Käyttötiedot	Arvo		
Käyttöpaine (sopivin)	3 bar	45 PSI	300 kPa
Käyttöpaine (maksimi)*	5 bar	70 PSI	500 kPa
Käyttöpaine (minimi)*	1 bar	14,5 PSI	100 kPa
Veden lämpötila (sopivin)	60 °C	140 °F	
Veden lämpötila (maksimi)	70 °C	158 °F	

* Tasainen paine on suositeltava.



Reguliarūs patikrinimai

- ▶ Periodiškai patikrinkite, ar jungtys ir dušų žarna neturi šių požymių:
 - Nesandarumas
 - Korozija
 - Mechaniniai pažeidimai
- ▶ Naudokite tik originalias atsargines dalis.
- ▶ Drėgnas ar vandenį leidžiančias žarnas pakeiskite.
- ▶ Pakeiskite žarnas, kurių paviršius surūdijęs arba oksidavęsis.
- ▶ Pakeiskite mechaninių pažeidimų požymius turinčias žarnas.

Žarnelių keitimas

- ▶ Nenaudokite veržliarakčio arba kitų įrankių žarnelėms tvirtinti čiaupo pusėje. Jas tvirtinkite tik rankomis.



- ▶ Prieš montavimą visus varždžius gerai praplaukite.

Ekspluataciniai duomenys	Vertė		
Darbinis slėgis (idealus)	3 barai	45 PSI	300 kPa
Darbinis slėgis (maks.)*	5 barai	70 PSI	500 kPa
Darbinis slėgis (maž.)*	1 baras	14,5 PSI	100 kPa
Vandens temperatūra (ideali)	60 °C	140 °F	
Vandens temperatūra (didž.)	70 °C	158 °F	

* Rekomenduojamas vienodas slėgis.



Regulāras pārbaudes

- ▶ Savienojumiem un dušas šļūtenēm regulāri jāpārbauda:
 - ūdensnecaurlaidība
 - korozijas pazīmes
 - mehānisku bojājumu pazīmes
- ▶ Izmantojiet tikai oriģinālās rezerves daļas.
- ▶ Norminiet mitrās vai pīlošās šļūtenes.
- ▶ Nomainiet šļūtenes, ja uz to virsmas redzamas rūsas vai oksidācijas pēdas.
- ▶ Nomainiet šļūtenes, ja tām redzamas mehānisku bojājumu pēdas.

Lokano cauruļu nomaīņa

- ▶ Neizmantojiet uzgriežņu atslēgu vai citus instrumentus, lai lokanās caurules uzstādītu pie krāna. To dariet tikai ar rokām.



- ▶ Pirms uzstādīšanas kārtīgi izskalojiet visas caurules.

Tehniskie dati	Vērtība		
Darbības spiediens (ideālais)	3 bar	45 PSI	300 kPa
Darbības spiediens (maks.)*	5 bar	70 PSI	500 kPa
Darbības spiediens (min.)*	1 bar	14,5 PSI	100 kPa
Ūdens temperatūra (ideālā)	60 °C	140 °F	
Ūdens temperatūra (maks.)	70 °C	158 °F	

* Ieteicams vienmērīgs spiediens.

ET



Periodilised kontrollid

- ▶ Kontrollīģe ūhendust ja dušivoolikuid periodiliseit jģrgneva osas:
 - veetihedus
 - korrosioon
 - mehaaniliseid kahjustuseid
- ▶ Kasutage ainult originaalvaruosi.
- ▶ Asendage niisked vģi tilkuvad voolikud.
- ▶ Asendage roostese vģi oksģdeerunud pinnaga voolikud.
- ▶ Asendage mehaaniliseid kahjustustega voolikud.

Paindosade vģljavahetamine

- ▶ Ārģe kasutage kraanipoolsete paindosade paigaldamiseks mutrivģiti eģa muid esemeid. Paigaldage need ainult kģsiti.



- ▶ Loputage enne paigaldamist torud korralikult lģbi.

Tģģandmed	Vģģrtus		
Tģģsurve (ģdeģalne)	3 baari	45 PSI	300 kPa
Tģģsurve (max)*	5 baari	70 PSI	500 kPa
Tģģsurve (min)*	1 baar	14,5 PSI	100 kPa
Vee temperatģur (ģdeģalne)	60 °C	140 F	
Vee temperatģur (max)	70 °C	158 F	

* soovituslik on vģrdne surve.



Pravidelné kontroly

- ▶ Pravidelně kontrolujte přípojovací hadičky a hadičky spršek:
 - zda jsou vodotěsné
 - zda nejsou zkorodované
 - zda nejsou mechanicky poškozené
- ▶ Používejte pouze originální náhradní díly.
- ▶ Vyměňte vlhké nebo kapající hadičky.
- ▶ Vyměňte hadičky s rezavým nebo zoxidovaným povrchem.
- ▶ Vyměňte hadičky, které vykazují známky mechanického poškození.

Výměna pružných dílů

- ▶ K montáži pružných dílů na stranu kohoutu nepoužívejte klíč ani žádné jiné nářadí. Montáž provádějte ručně.



- ▶ Před montáží důkladně propláchněte všechny trubky.

Provozní údaje	Hodnota		
Provozní tlak (ideální)	3 bar	45 PSI	300 kPa
Provozní tlak (max.)*	5 bar	70 PSI	500 kPa
Provozní tlak (min.)*	1 bar	14,5 PSI	100 kPa
Teplota vody (ideální)	60 °C	140 °F	
Teplota vody (max.)	70 °C	158 °F	

* Doporučuje se vyrovnaný tlak.



Kontrola okresowa

- ▶ Sprawdzać węże przyłączeniowe i węże do wyciąganej wylewki pod kątem:
 - wodoszczelności
 - korozji
 - uszkodzeń mechanicznych
- ▶ Używać wyłącznie oryginalnych części zamiennych.
- ▶ Wymienić nasiąknięte lub nieszczelne węże.
- ▶ Wymienić węże, których powierzchnia jest skorodowana lub utleniona.
- ▶ Wymienić węże, na których widoczne są uszkodzenia mechaniczne.

Wymiana elementów elastycznych

- ▶ Nie używać klucza lub innych narzędzi do montażu elementów elastycznych po stronie kranu. Montować tylko ręcznie.



- ▶ Před montáží důkladně přepláchněte všechny rury.

Dane eksploatacyjne	Wartość
Ciśnienie robocze (optymalne)	3 bary
Ciśnienie robocze (maks.)*	5 barów
Ciśnienie robocze (min.)*	1 bar
Temperatura wody (optymalna)	60 °C
Temperatura wody (maks.)	70 °C

* Wartości ciśnienia powinny być jednakowe.

SK



Pravidelné kontroly

- ▶ Pravidelne preverte spojovacie a sprchovacie hadice vzhľadom na:
 - Vodotesnosť
 - Koróziu
 - Mechanické poškodenie
- ▶ Používajte iba originálne náhradné diely.
- ▶ Vymeňte vlhké alebo netesniace hadice.
- ▶ Vymeňte hadice s hrdzavým alebo zoxidovaným povrchom.
- ▶ Vymeňte hadice, ktoré majú známky mechanického poškodenia.

Výmena hadíc

- ▶ Nepoužívajte kľúč ani iné nástroje na montáž hadíc nastrane kohútika. Namontujte hadice iba ručne.



- ▶ Dôkladne prepláchnite všetky hadice pred inštaláciou.

Prevádzkové údaje	Hodnota		
Prevádzkový tlak (ideálny)	3 bary	45 PSI	300 kPa
Prevádzkový tlak (max.)*	5 barov	70 PSI	500 kPa
Prevádzkový tlak (min.)*	1 bar	14,5 PSI	100 kPa
Teplota vody (ideálna)	60 °C	140 °F	
Teplota vody (max.)	70 °C	158 °F	

* Odporúča sa rovnaký tlak.



Intervalni pregledi

- ▶ Povezavo in cevi tuša preverite glede naslednjega:
 - vodotesnost
 - korozija
 - mehanske poškodbe.
- ▶ Uporabljajte samo originalne rezervne dele.
- ▶ Zamenjajte vlažne cevi oz. cevi, ki puščajo.
- ▶ Zamenjajte cevi z zarjavlimi ali oksidiranimi površinami.
- ▶ Zamenjajte cevi, ki kažejo znake mehanskih poškodb.

Zamenjava gibkih cevi

- ▶ Za namestitev gibkih cevi na armaturo ne uporabljajte ključa ali drugih orodij. Namestite jih izključno z roko.



- ▶ Pred namestitvijo vse cevi temeljito izperite.

Delovni podatki	Vrednost		
Delovni tlak (idealni)	3 bari	45 PSI	300 kPa
Delovni tlak (najv.)*	5 barov	70 PSI	500 kPa
Delovni tlak (najm.)*	1 bar	14,5 PSI	100 kPa
Temperatura vode (idealna)	60 °C	140 °F	
Temperatura vode (najv.)	70 °C	158 °F	

* Priporočen je enakomeren tlak.



Redovne prevere

- ▶ Kod priključka i creva tuša redovno proveravati sledeće:
 - Vodootpornost
 - Korozija
 - Mehaničko oštećenje
- ▶ Koristiti samo originalne rezervne delove.
- ▶ Zameniti creva za paru ili kapanje.
- ▶ Zameniti creva sa zarđalim ili oksidiranim površinama.
- ▶ Zameniti creva na kojima postoje znakovi mehaničkog oštećenja.

Zamena fleksibilnih delova

- ▶ Ne koristite ključ niti druge predmete za montiranje fleksibilnih delova sa strane slavine. Njih montirajte isključivo rukom.



- Temeljno isprati sva creva pre instalacije.

Radni parametri	Vrednost		
Radni pritisak (idealni)	3 bara	45 PSI	300 kPa
Radni pritisak (maks.)*	5 bara	70 PSI	500 kPa
Radni pritisak (min.)*	1 bar	14,5 PSI	100 kPa
Temperatura vode (idealna)	60 °C	140 °F	
Temperatura vode (maks.)	70 °C	158 °F	

* Preporučuje se podjednaki pritisak.

HU



Rendszeres ellenőrzések

- Rendszeresen ellenőrizze a csatlakozót és a zuhanytömlőt a következők tekintetében:
 - vízvívárgás
 - korrózió
 - mechanikus sérülés
- Kizárólag eredeti pótalkatrészeket használjon.
- Cserélje ki a szivárgó vagy csöpögő tömlőket.
- Cserélje ki a rozsdás vagy oxidált felületű tömlőket.
- Cserélje ki a tömlőket, ha mechanikus sérülés van rajtuk.

Flexibilis cső cseréje

- Ne használjon csavarkulcsot vagy egyéb szerszámot a flexibilis cső csapra történő felszereléséhez. Ezeket csak kézzel szerelje fel.



- Szerelés előtt öblítse át alaposan a tömlőket.

Üzemi adatok	Érték		
Üzemi nyomás (ideális)	3 bar	45 psi	300 kPa
Üzemi nyomás (max.)*	5 bar	70 psi	500 kPa
Üzemi nyomás (min.)*	1 bar	14,5 psi	100 kPa
Vizhőmérséklet (ideális)	60 °C	140 °F	
Vizhőmérséklet (max.)	70 °C	158 °F	

* Állandó nyomás biztosítása ajánlott.



Povremene provjere

- ▶ Povremeno provjerite spoj i crijeva za tuševe s obzirom na sljedeće:
 - Vodonepropusnost
 - Korozija
 - Mehanička oštećenja
- ▶ Upotrebljavajte samo originalne rezervne dijelove.
- ▶ Zamijenite crijeva koja su vlažna ili cure.
- ▶ Zamijenite crijeva s hrđavim ili oksidiranim površinama.
- ▶ Zamijenite crijeva koja pokazuju znakove mehaničkog oštećenja.

Zamjena gumenih cijevi

- ▶ Zabranjena je upotreba ključa ili nekih drugih predmeta za postavljanje gumenih cijevi na strani slavine. Postavite ih rukom.



- ▶ Prije instalacije temeljito isperite sve cijevi.

Radni podaci	Vrijednost		
Radni tlak (idealni)	3 bar	45 PSI	300 kPa
Radni tlak (maks.)*	5 bar	70 PSI	500 kPa
Radni tlak (min.)*	1 bar	14,5 PSI	100 kPa
Temperatura vode (idealna)	60 °C	140 °F	
Temperatura vode (maks.)	70 °C	158 °F	

* Preporučuje se jednak tlak.



Verificări periodice

- ▶ Verificați periodic conexiunile și orificiile dușului pentru următoarele:
 - Etanșeitate
 - Coroziune
 - Defecțiuni mecanice
- ▶ Utilizați numai piesele originale de schimb.
- ▶ Înlocuiți furtunurile deteriorate sau care picură.
- ▶ Înlocuiți furtunurile ruginite sau cu suprafața oxidată.
- ▶ Înlocuiți furtunurile care arată semne de deteriorare mecanică.

Înlocuirea componentelor flexibile

- ▶ Nu utilizați o chei fixă sau alte obiecte pentru a monta componentele flexibile pe partea robinetului. Acestea trebuie montate doar manual.



- ▶ Înainte de instalare evacuați complet apa din conducte.

Date de operare	Valoare		
Presiunea de operare (ideală)	3 bari	45 PSI	300 kPa
Presiunea de operare (max.)*	5 bari	70 PSI	500 kPa
Presiunea de operare (min.)*	1 bar	14,5 PSI	100 kPa
Temperatura apei (ideală)	60 °C	140 °F	
Temperatura apei (max.)	70 °C	158 °F	

*Se recomandă presiune constantă.

BG



Периодични проверки

- ▶ Редовно проверявайте свързващите маркучи и маркучите на батерията за следното:
 - Водонепропускливост
 - Корозия
 - Механични повреди
- ▶ Използвайте само оригинални резервни части.
- ▶ Подменяйте влажни или капещи маркучи.
- ▶ Подменяйте маркучи с ръждясали или окислени повърхности.
- ▶ Подменяйте маркучи с признаци за механична повреда.

Смяна на гъвкавите части

- ▶ Не използвайте гаечен ключ или други елементи за монтиране на гъвкавите части от страната на крана. Монтирайте ги само на ръка.



- ▶ Продушайте внимателно всички тръби преди монтаж.

Данни за експлоатация	Стойност		
Работно налягане (оптимално)	3 бара	45 PSI	300 kPa
Работно налягане (макс.)*	5 бара	70 PSI	500 kPa
Работно налягане (мин.)*	1 бар	14,5 PSI	100 kPa
Температура на водата (оптимална)	60 °C	140 °F	
Температура на водата (макс.)	70 °C	158 °F	

* Препоръчва се равномерно налягане.



Періодичні перевірки

- ▶ Час від часу слід перевіряти з'єднання та сантехнічні шланги на наявність таких ознак:
 - порушення герметичності
 - корозія
 - механічні пошкодження
- ▶ Використовуйте лише оригінальні запасні частини.
- ▶ Замінійте відсирілі шланги та шланги, що протікають.
- ▶ Замінійте шланги з іржавими поверхнями та поверхнями, що окислилися.
- ▶ Замінійте шланги з ознаками механічних пошкоджень.

Заміна гнучких елементів

- ▶ Не використовуйте гайковий ключ або інші інструменти під час монтажу гнучких елементів на стороні крана. Монтуйте їх тільки вручну.



- ▶ Перед встановленням крана слід ретельно промити всі труби.

Техніко-експлуатаційні дані	Значення		
Робочий тиск (ідеальний)	3 бар	45 фунтів/кв. дюйм	300 кПа
Робочий тиск (макс.)*	5 бар	70 фунтів/кв. дюйм	500 кПа
Робочий тиск (мін.)*	1 бар	14,5 фунта/кв. дюйм	100 кПа
Температура води (ідеальна)	60° C	140° F	
Температура води (макс.)	70° C	158° F	

* Рекомендовано застосовувати однаковий тиск.



Периодические проверки

- ▶ Время от времени следует проверять соединения и сантехнические шланги на наличие следующих признаков:
 - нарушение герметичности
 - коррозия
 - механические повреждения
- ▶ Используйте только оригинальные запасные части.
- ▶ Осуществляйте замену отсыревших или протекающих шлангов.
- ▶ Осуществляйте замену шлангов со ржавыми или окислившимися поверхностями.
- ▶ Осуществляйте замену шлангов с признаками механических повреждений.

Замена гибких трубопроводов

- ▶ Не используйте гаечный ключ или другие инструменты для установки гибких трубопроводов со стороны крана. Устанавливайте их только вручную.



- Перед установкой крана необходимо тщательно промыть все трубы.

Технико-эксплуатационные данные	Значение		
Рабочее давление (идеальное)	3 бар	45 фунтов/кв. дюйм	300 кПа
Рабочее давление (макс.)*	5 бар	70 фунтов/кв. дюйм	500 кПа
Рабочее давление (мин.)*	1 бар	14,5 фунта/кв. дюйм	100 кПа
Температура воды (идеальная)	60° C	140° F	
Температура воды (макс.)	70° C	158° F	

* Рекомендовано применять одинаковое давление.

TR



Periyodik kontroller

- Bağlantı ve dış hortumlarını periyodik olarak aşağıdakiler bakımından kontrol edin:
 - Su geçirmezlik
 - Korozyon
 - Fiziksel hasar
- Sadece orijinal yedek parçaları kullanın.
- Nemli veya su damlatan hortumları değiştirin.
- Yüzeyleri paslı veya oksitlenmiş olan hortumları değiştirin.
- Fiziksel hasar belirtisi gösteren hortumları değiştirin.

Esnek parçaların değişimi

- Musluk tarafına esnek parçaları monte ederken anahtar veya başka bir nesne kullanmayın. Bunları yalnızca elle monte edin.



- Monte etmeden önce tüm boruları iyice yıkayın.

Çalışma verileri	Değer		
Çalışma basıncı (ideal)	3 bar	45 PSI	300 kPa
Çalışma basıncı (maks.)*	5 bar	70 PSI	500 kPa
Çalışma basıncı (min.)*	1 bar	14,5 PSI	100 kPa
Su sıcaklığı (ideal)	60 °C	140°F	
Su sıcaklığı (maks.)	70 °C	158°F	

* Eşit basınç tavsiye edilir.



定期检查

- ▶ 定期检查连接和淋浴软管的以下方面：
 - 不透水性
 - 腐蚀程度
 - 机械损伤
- ▶ 仅使用原厂零件。
- ▶ 更换潮湿或流水的软管。
- ▶ 更换表面生锈或氧化的软管。
- ▶ 更换有机械损伤迹象的软管。

软管更换

- ▶ 不要使用扳手或者其他工具将软管安装到水龙头一侧。 仅可手工安装。



- ▶ 在安装前彻底冲洗所有管道。

操作数据	值		
操作压力 (理想值)	3 bar	45 PSI	300 kPa
操作压力 (最大值)*	5 bar	70 PSI	500 kPa
操作压力 (最小值)*	1 bar	14.5 PSI	100 kPa
水温 (理想值)	60 °C	140°F	
水温 (最高值)	70 °C	158°F	

* 建议使用等压。

التفحوصات الدورية

تلميح: حوض الاستخدام ووصلاته ايشك لتدري بطّح ان الامور التالية:

إحكام الربط

التأكد

التلف الميكانيكي

حداً قطع الغيار الأصلية فقط

استبدال الخراطيم التالفة أو المشققة

خراطيم الصلدة أو الأسط حاله مؤكسده

دال الخراطيم التي يظهر عليها علامات التلف الميكانيكي.

استبدال الأجزاء المرنة

لا تستخدم مفتاح أو أشياء أخرى لتثبيت الأجزاء المرنة بجانب الصنوبر.

قم بتثبيت هذه الأجزاء باليد فقط.

مسح جميع الأنابيب جيداً قبل التركيب.



بيانات التشغيل		القيمة
ضغط التشغيل (المثالي)	3 بار	4.5 رطلاً 1 كل بوصة مربعة 300 كيلو باسكال
ضغط التشغيل (الحد الأقصى)*	5 بار	7.0 رطلاً 1 كل بوصة مربعة 500 كيلو باسكال
ضغط التشغيل (الحد الأدنى)*	1 بار	14.5 رطل 1 كل بوصة مربعة 100 كيلو باسكال
درجة حرارة الماء (المثالية)	60 درجة سليزيوس	140 درجة فهرنهايت
درجة حرارة الماء (الحد الأقصى)	70 درجة سليزيوس	150 درجة فهرنهايت

* يتصح باستخدام الضغط المتعامل.

i**A**

Swivel spout L shape

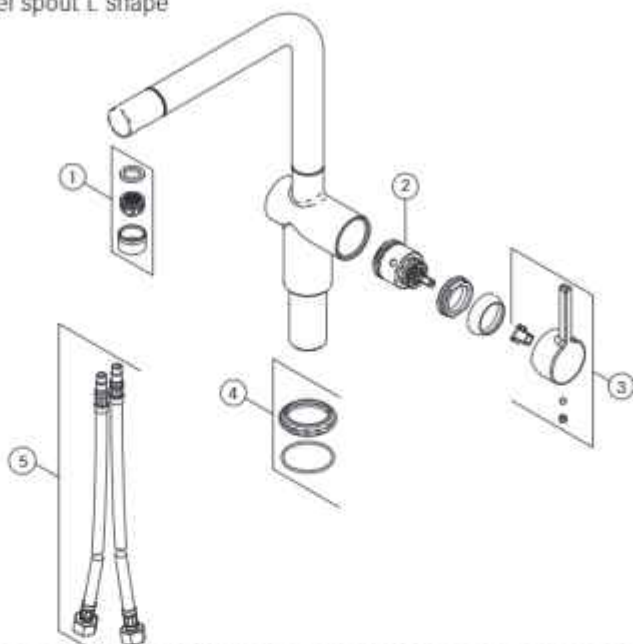
**B**

Swivel spout J shape

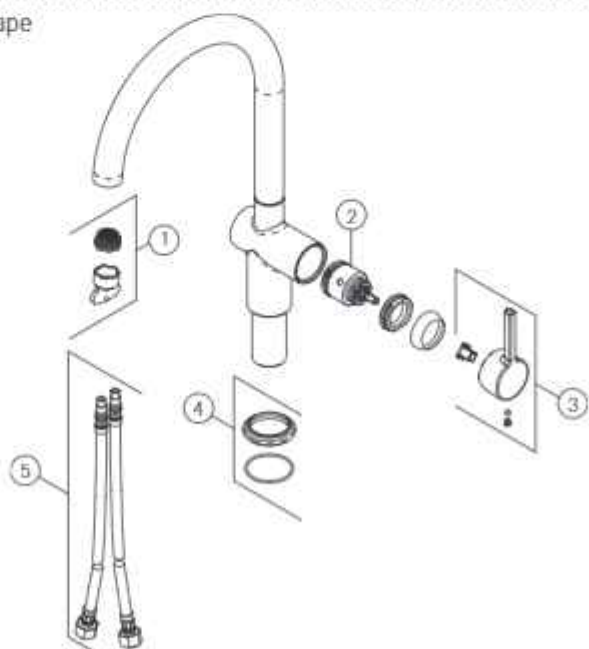



C

Semi-pro 2 jets

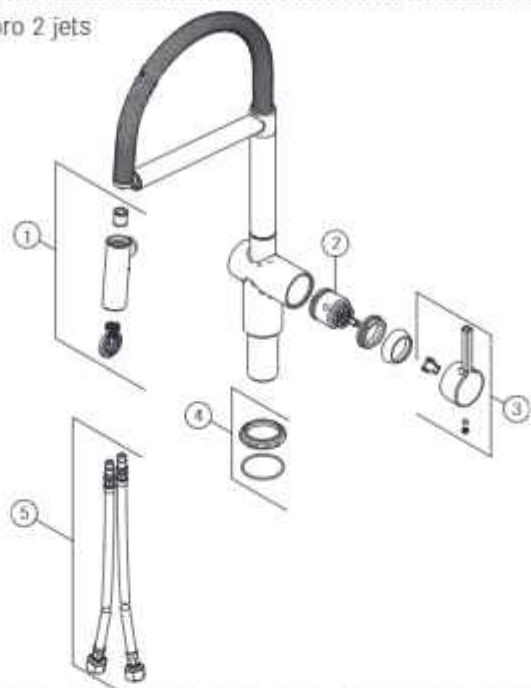

D

Pull-out L shape 2 jets

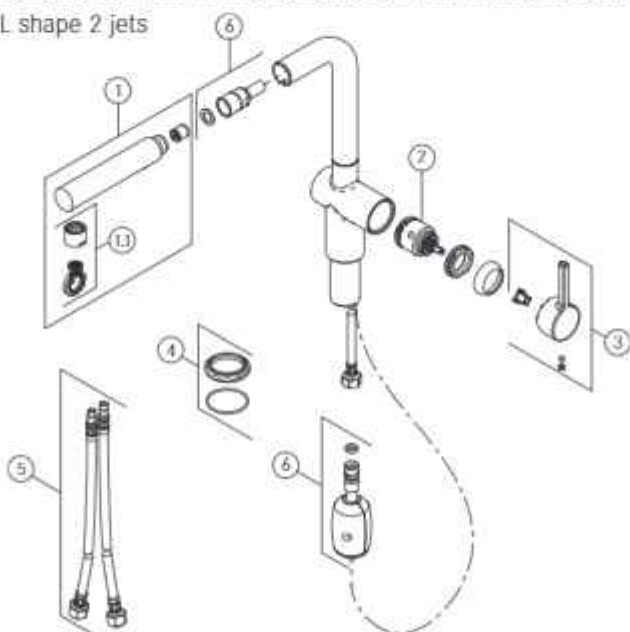

i**E**

Pull - down J shape 2 jets

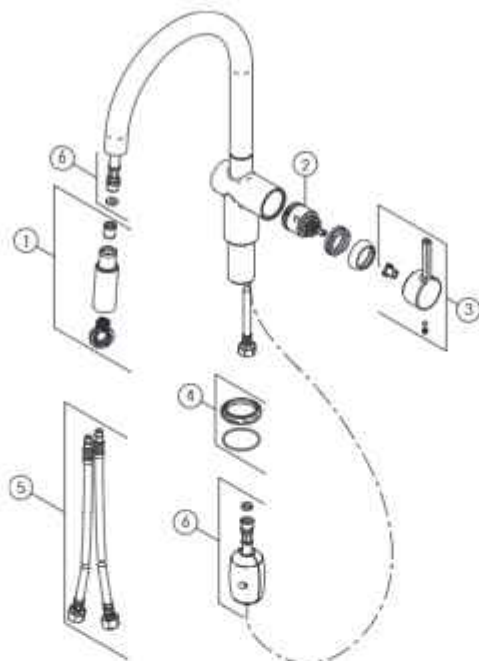
**F**

Window Swivel spout

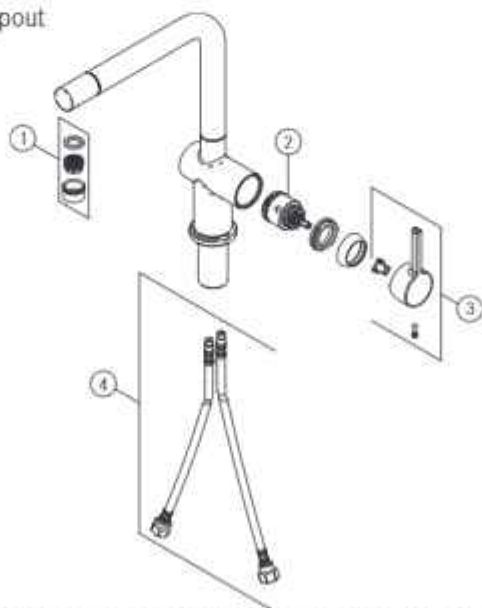



G

Window pull-out 2 jets

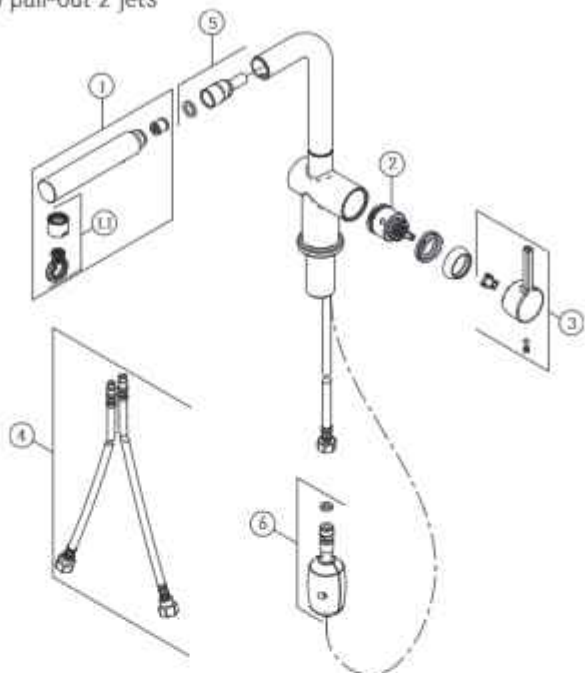

H

Window Swivel spout LP

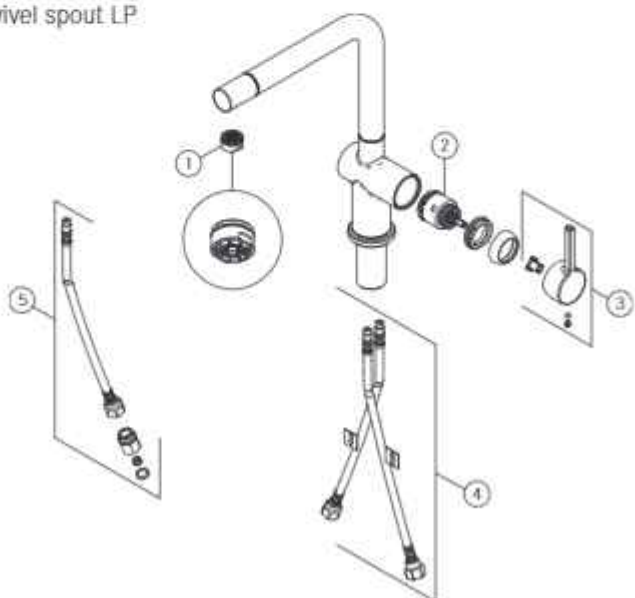



Window pull-out 1 jet LP

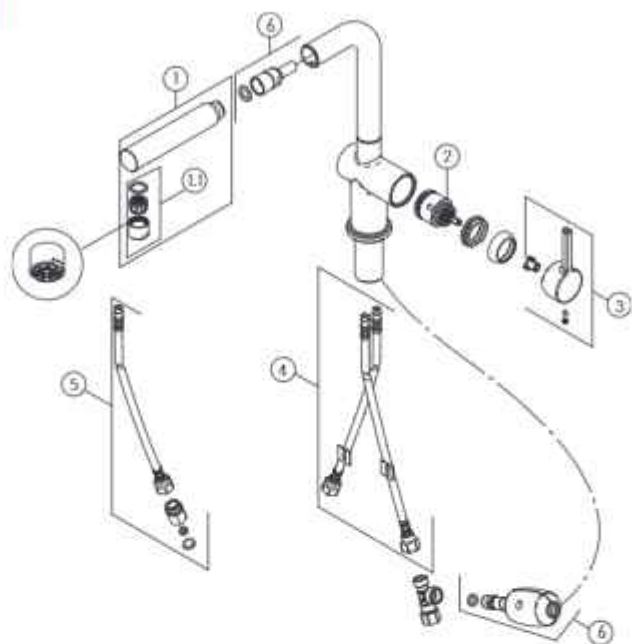

Pull-out L shape 1 jet

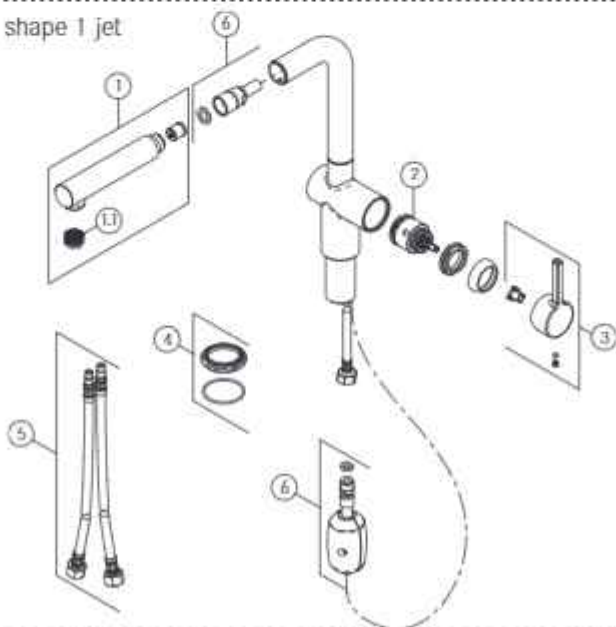

Argentina

Industrias Spar San Luis S.A.
Buenos Aires 1008
Phone +54 11 4311 7656

Australia

Franke AU
Melbourne 3175
Phone +61 3 9700 9100

Belgium

Franke NV
9400 Niriove
Phone +32 54 310 111

Brazil

Franke Sistemas de
Cozinhas Ltda
89 219-600 Joinville-SC
Phone 0800-4773000

Canada

Franke Kindred Canada Ltd.
Midland, ON L4R 4K9
Phone +1 866 687 7465

China

Franke (China) Kitchen
Systems Co., Ltd.
Heshan, Guangdong, 529700
Phone 400 882 9898

Czech Republic

Franke s.r.o.
190 00 Praha 9
Phone +420 281 090 445

Denmark

Franke KS Denmark
8520 Lystrup
Phone +45 8624 9024

Egypt

Al Sharg for Ceramic and
Porcelain - Mozdan
Nasr City, Cairo, Egypt
Phone +201000038122

Finland

Franke Finland Oy
76850 Naarajärvi
Phone +358 15 341 11

France

Franke France S.A.S.
60230 Chambly
Phone +33 330 289 400

Germany

Franke GmbH
79713 Bad Säckingen
Phone +49 7761 52 199

Greece

Franke Hellas S.A.
19003 Markopoulo Attikis
(Athens)
Phone +30 22991 500 00

Hong Kong SAR

Franke Asia Hong Kong
Quarry Bay
Phone +852 3184 1900

India

Franke Faber India Private
Limited
Pune 412208
Phone 1800 209 3484

Italy

Franke S.p.A.
37019 Peschiera del Garda
Toll-free number 800 359 359

Kazakhstan

Franke Kazakhstan Ltd.
040918 Almaty City
Phone +7 727 297 3812

New Zealand

PR Kitchens
Auckland 2150
Phone +64 9 964 0400

Norway

Franke KS Norway
8520 Lystrup, Denmark
Phone +47 35 566 450

Poland

Franke Polska Sp. z o.o.
06-090 Raszyn
Phone +48 22 716700

Portugal

Franke Portugal S.A.
2735-531 Cacém
Phone +351 21 426 9670

Romania

Franke Romania SRL
Pantelimon 077145
Phone +40 21 350 1550

Russia

Franke Russia GmbH
248033 Kaluga
Phone +8 800 555 1255

Singapore

Franke Singapore Pte Ltd
33 Ubi Ave 3
01-38 Vertex
Phone +65 9838 2542

Slovak Republic

Franke Slovakia s.r.o.
013 24 Strečno
Phone +420 281 090 445

South Africa

Franke South Africa
Durban 4052
Phone +27 31 450 6300

Spain

Franke España S.A.U.
08174 Sant Cugat del Valles
Phone +34 934 456 768

Sweden

Franke Futurum AB
930 47 Byske
Phone +46 912 405 00

Switzerland

Franke Küchentechnik AG
4663 Aarburg
Phone +41 800 583 243

Thailand

Franke (Thailand) Co., Ltd.
Bangkok 10110
Phone +66 2 013 7900

The Netherlands

Franke Nederland B.V.
5700 AD Helmond
Phone +31 492 585 111

Turkey

Franke MutfaK ve Banyo
Sistemleri Sanayi
ve Ticaret A.Ş.
41480 Gebze Kocaeli/Turkey
Phone +90 262 644 6695

Ukraine

Franke Ukraina LLC
01042 Kyiv
Phone 0 800 301 801

United Arab Emirates

Franke LLC
Ras Al Khaimah
Phone +9717 203 4700

United Kingdom

Franke UK Ltd.
Manchester M22 5WB
Phone +44 161 436 6280

USA

Franke Home Solutions, LLC
Smyrna, TN 37167
Phone 1 800 626 5771